

# FESTOOL

## **ETS Series Random Orbit Sanders**



### ***ETS 125/3 EQ Plus, ETS 150/3 EQ Plus, ETS 150/5 EQ Plus Supplemental User's Manual***



**WARNING** To reduce the risk of serious injury, read and understand all safety precautions and instructions in this manual before using this tool.

---

## Limited Warranty<sup>1</sup>

### 30 Day Money Back Guarantee

Buy with confidence. If you are not completely satisfied, return your tool<sup>2</sup> to the selling dealer within 30 days and you will receive a refund of either your purchase price or the lowest retail price at which the same item has been offered since your date of purchase. Freight charges are not refundable.

---

### Service All-Inclusive<sup>®</sup> Warranty

Festool USA warrants that all new Festool power tools<sup>3</sup> purchased from authorized dealers in the U.S. and Canada will be free from defects in materials and workmanship for a term of three years from the date of original retail purchase.

---

### Conditions of Service All-Inclusive Warranty

This warranty applies for three years from the date of original retail purchase. Proof of purchase is required. This warranty is void if the tool is not used, operated, repaired and maintained in accordance with the tool's instruction manual.

---

### Excluded from this warranty's coverage are:

- ▶ Accessories and/or attachments, including, but not limited to, saw blades, drill bits, router bits, sanding discs and apparel
- ▶ Tools purchased from outside of the U.S. or Canada
- ▶ Repairs or replacements not performed by an authorized Festool Service Center, outside of routine maintenance as set forth in the instruction manual
- ▶ Parts or components not supplied by Festool or that have been modified
- ▶ Damage caused by misuse, abuse, accident, impact, abnormal wear and tear, improper storage and/or exposure to the elements, or neglect
- ▶ Damage caused by anything other than defects in materials and workmanship
- ▶ Normal adjustments and recommended maintenance as set forth in the tool's instruction manual
- ▶ Damage from the operation of the tool at a voltage or frequency different from the tool's rating, including the use of transformers

1 The following is an exemplar Festool limited warranty. The actual warranty that comes with your power tool is controlling.

2 Tool must be returned in complete and whole condition as supplied to include Systainer, cutter, blade, power cord, etc.

3 For purposes of this warranty, power tools are defined as any Festool branded product that bears a serial number (S.Nr. or M.Nr.).

4 To determine if your application is excluded from the warranty under this condition, please contact the Festool Service Center at 800.554.8741

---

## Repairs

If your Festool power tool requires repair, whether it be warranty or non-warranty, you must contact our Service

- ▶ Damage resulting from the use of any non-Festool accessories or attachments
- ▶ Tools used in high volume industrial applications<sup>4</sup>

Should any failure covered by this Limited Warranty occur, the purchaser must contact Festool through our website, [www.festoolusa.com/SAI](http://www.festoolusa.com/SAI), or call 888.337.8600 for authorization and shipping information. For purchases made in Canada, contact our website, [www.festoolcanada.com/SAI](http://www.festoolcanada.com/SAI) or call 613.363.0169. Festool, in its sole discretion, may elect to repair, replace or refund the purchase price of any tool covered by this Limited Warranty that is found to be defective, at no cost to the purchaser. Warranty returns will be processed by Festool according to normal work flow and availability of replacement parts and components. Festool will issue a prepaid shipping label for return of the tool to the Festool Service Center and will also return the repaired tool freight prepaid, if the repair or replacement is covered under this Limited Warranty.

FESTOOL SHALL NOT BE LIABLE FOR ANY CONSEQUENTIAL, INCIDENTAL OR SPECIAL DAMAGES REGARDLESS OF THE THEORY OF LAW ON WHICH THE CLAIM IS BASED. ALL WARRANTIES IMPLIED BY STATE LAW, INCLUDING THE IMPLIED WARRANTIES OF MERCHANTABILITY AND FITNESS FOR A PARTICULAR PURPOSE ARE HEREBY LIMITED TO THE DURATION OF THREE YEARS.

SOME STATES IN THE U.S. AND SOME CANADIAN PROVINCES DO NOT ALLOW EXCLUSIONS/LIMITATIONS OF INCIDENTAL OR CONSEQUENTIAL DAMAGES AND/OR LIMITATIONS ON HOW LONG AN IMPLIED WARRANTY LASTS, SO THE ABOVE LIMITATION MAY NOT APPLY TO YOU. THIS WARRANTY GIVES YOU SPECIFIC LEGAL RIGHTS, AND YOU MAY ALSO HAVE OTHER RIGHTS THAT VARY FROM STATE TO STATE IN THE U.S. AND FROM PROVINCE TO PROVINCE IN CANADA.

With the exception of any warranties implied by state or province law as limited above, the foregoing limited warranty is exclusive and in lieu of all other warranties, guarantees, agreements, and similar obligations of Festool. No agent, representative, distributor, dealer, or employee of Festool has the authority to increase or otherwise modify the obligations or limitations of this warranty.

---

### Warrantor:

Festool USA  
Festool Canada

Phone: USA—888.337.8600  
Canada—613.363.0169

400 N Enterprise Dr.  
Lebanon, IN 46052

[festoolusa.com/SAI](http://festoolusa.com/SAI)  
[festoolcanada.com/SAI](http://festoolcanada.com/SAI)

Department at 888-337-8600 (613-363-0169 Canada) for authorization and address details.

---

## Liability Statement

This product has been built to the high standards of Festool. Please do not attempt to operate or repair this equipment without adequate training. Any use, operation, or repair in contravention of this document is at your own risk. By acceptance of this system you hereby assume all liability consequent to your

use or misuse of this equipment. Festool assumes no liability for incidental, special, or consequential damage of any kind. Equipment specifications, applications, and options are subject to change at the sole discretion of Festool without notice.

---

## Proprietary Notice

All drawings and information herein are the property of Festool, TTS Tooltechnic Systems AG & Co. KG. All unauthorized use and reproduction is prohibited.

Written and Illustrated by Rick Christopherson.

© 2014 TTS Tooltechnic Systems AG & Co. KG

Festool USA is a division of Tooltechnic Systems, LLC.

Festool is a trademark and service mark of TTS Tooltechnic Systems AG & Co. KG

Plug-It and Systainer are registered trademarks of TTS Tooltechnic Systems AG & Co. KG

[www.festoolusa.com](http://www.festoolusa.com)

# Contents

<b>About This Manual</b> .....	<b>3</b>	<b>Setup</b> .....	<b>10</b>
Tool Symbols .....	3	Changing Sanding Pads.....	10
<b>General Power Tool Safety Warnings</b> .....	<b>4</b>	Choosing the Correct Sanding Pad .....	10
Work Area Safety .....	4	Changing Sandpaper .....	10
Electrical Safety .....	4	Using the Turbo Collection Bag.....	11
Personal Safety .....	4	Connecting a Dust Extractor .....	11
Power Tool Use and Care .....	4	Connecting the Plug-It Power Cord .....	12
Service .....	5	Setting the Variable Speed .....	12
Specific Safety Rules for Sanders .....	5	Turning on the Sander .....	12
Respiratory Exposure Safety Warnings .....	5	<b>Operation</b> .....	<b>13</b>
<b>Sander Overview</b> .....	<b>5</b>	Pad Brake .....	13
Intended Use.....	5	Using Dust Extraction .....	13
Technical Specifications.....	5	Choosing Hand Positions .....	14
Functional Description .....	6	Working With Sanding Grits.....	14
Sanding Action .....	7	Sanding Techniques.....	15
Dual-Action.....	7	Establishing Optimal Sanding Pressure .....	15
Random Orbit .....	7	Sanding Pattern and Movement .....	15
Optimizing Random Orbit.....	7	<b>Maintenance and Adjustment</b> .....	<b>17</b>
Anatomy of Sandpaper .....	8	Routine Maintenance .....	17
Choosing the Appropriate Grit .....	9	Troubleshooting .....	17
Best Sandpaper for the Task .....	9	Motor Brush Replacement .....	18
		ETS 125 Motor Brushes .....	18
		ETS 150 Motor Brushes .....	20

## About This Manual

### Save These Instructions

It is important for you to read and understand this manual. The information it contains relates to protecting YOUR SAFETY and PREVENTING PROBLEMS. The symbols below are used to help you recognize this information.



**WARNING!** Indicates a potentially hazardous situation which, if not avoided, could result in death or serious injury.



**CAUTION!** Indicates a potentially hazardous situation which, if not avoided, could result in minor or moderate injury.



**NOTICE:** Indicates a potential situation which, if not avoided, can result in property damage or damage to the tool.



**Note:** Indicates information, notes, or tips for improving your success using the tool.

### Tool Symbols

V	Volts
W	Watts
Hz	Hertz
~	Alternating Current (AC)
n	No-load Speed
□	Class II Double Insulated

# General Power Tool Safety Warnings



**WARNING! Read all safety warnings and instructions.** Failure to follow the warnings and instructions may result in electric shock, fire, and/or serious injury.

**Save all warnings and instructions for future reference.**

## Work Area Safety

- ▶ Keep your work area clean and well lit. Cluttered or dark work areas invite accidents.
- ▶ Do not operate power tools in explosive atmospheres, such as in the presence of flammable liquids, gases, or dust. Power tools create sparks which may ignite the dust or fumes.
- ▶ Keep children and bystanders away while operating a power tool. Distractions can cause you to lose control.

## Electrical Safety

- ▶ Power tool plugs must match the outlet. Never modify the plug in any way. Do not use any adapter plugs with earthed (grounded) power tools. Unmodified plugs and matching outlets will reduce risk of electric shock.
- ▶ Avoid body contact with earthed or grounded surfaces such as pipes, radiators, ranges and refrigerators. There is an increased risk of electric shock if your body is earthed or grounded.
- ▶ Do not expose power tools to rain or wet conditions. Water entering a power tool will increase the risk of electric shock.
- ▶ Do not abuse the cord. Never use the cord for carrying, pulling, or unplugging the power tool. Keep cord away from heat, oil, sharp edges or moving parts. Damaged or entangled cords increase the risk of electric shock.
- ▶ When operating a power tool outdoors, use an extension cord suitable for outdoor use. Use of a cord for outdoor use reduces the risk of electric shock.
- ▶ If operating a power tool in a damp location is unavoidable, use a ground fault circuit interrupter (GFCI) protected supply. Use of a GFCI reduces the risk of electric shock.
- ▶ Never use an extension cord that is damaged, including cuts, exposed wires, or bent/missing prongs. Damaged extension cords increase the risk of fire or electric shock.
- ▶ Use only extension cords rated for the purpose.
- ▶ Use only extension cords rated for the amperage of this tool and the length of the cord. Using too small of an extension cord can cause the cord to overheat.

### Extension Cord Ratings

Cord Length	Size (AWG)
<50 Ft.	14
50-100 Ft.	12
>100 Ft.	Not recommended

## Personal Safety

- ▶ Stay alert, watch what you are doing, and use common sense when operating a power tool. Do not use a power tool while tired or under the influence of drugs, alcohol, or medication. A moment of inattention while operating power tools may result in serious personal injury.
- ▶ Use personal protective equipment. Always wear eye protection. Protective equipment such as dust mask, non-skid safety shoes, hard hat, or hearing protection used for appropriate conditions will reduce personal injuries.
- ▶ Prevent unintentional starting. Ensure the switch is in the off-position before connecting to power source, picking up, or carrying the tool. Carrying power tools with your finger on the switch or energizing power tools that have the switch on invites accidents.
- ▶ Remove adjusting key or wrench before turning the power tool on. A wrench or a key that is left attached to a rotating part of the tool may result in personal injury.
- ▶ Do not overreach. Keep proper footing and balance at all times. This enables better control of the tool in unexpected situations.
- ▶ Dress properly. Do not wear loose clothing or jewelry. Keep your hair, clothing, and gloves away from moving parts. Loose clothes, jewelry, or long hair can be caught in moving parts.
- ▶ If devices are provided for the connection of dust extraction and collection facilities, ensure these are connected and properly used. Use of dust collection can reduce dust-related hazards.
- ▶ Always wear safety glasses complying with ANSI Z87.1. Ordinary glasses are not proper protection.

## Power Tool Use and Care

- ▶ Do not force the power tool. Use the correct power tool for your application. The correct power tool will do the job better and safer at the rate for which it is designed.
- ▶ Do not use the power tool if the switch does not turn it on and off. Any power tool that cannot be controlled with the switch is dangerous and must be repaired.
- ▶ Disconnect the plug from the power source before making any adjustments, changing accessories, or storing the tool. Such preventive safety measures reduce the risk of starting the tool accidentally.
- ▶ Store idle tools out of reach of children and do not allow persons unfamiliar with the power tool or these instructions to operate the power tool. Power tools are dangerous in the hands of untrained users.
- ▶ Maintain power tools. Check for misalignment or binding of moving parts, breakage of parts and any other condition that may affect the power tool's operation. If damaged, have the power tool repaired before use. Many accidents are caused by poorly maintained power tools.
- ▶ Keep cutting tools sharp and clean. Properly maintained tools with sharp cutting edges are less likely to bind and are easier to control.
- ▶ Use the power tool, accessories, and tool bits etc. in accordance with these instructions, taking into account the working

conditions and the work to be performed. Use of the power tool for operations different from those intended could result in a hazardous situation.

- ▶ To reduce the risk of serious injury, never alter or misuse the power tool.

---

## Service

- ▶ Have your power tool serviced by a qualified repair person using only identical replacement parts. This will ensure that

the safety of the power tool is maintained.

---

## Specific Safety Rules for Sanders

- ▶ Know the material you are sanding and take precautions accordingly. Some materials contain chemicals, elements, or fibers which may be toxic or harmful when abraded. Take caution to prevent dust or vapor inhalation and skin contact.
- ▶ Always perform sanding in a well ventilated area and use personal respiratory protection.
- ▶ Do not use in wet environments. Ingestion of water into the motor may result in electrocution hazard.
- ▶ Do not use the sander if the sanding pad fails to retain the sanding disk. Replace the sanding pad. A loose sanding disk can come free and cause personal injury.
- ▶ Take care when disposing of fine sanding dust. Fine particle dust may become explosive. Do not throw sanding dust on an open flame.
- ▶ Never sand materials containing asbestos.

---

## Respiratory Exposure Safety Warnings

Substantial or repeated inhalation of dust and other airborne contaminants, in particular those with a smaller particle size, may cause respiratory or other illnesses. Various dusts created by power sanding, sawing, grinding, drilling and other construction activities contain chemicals or substances known (to the State of California and others) to cause cancer, birth defects or other reproductive harm. Some examples of these chemicals/substances are: lead from lead-based paints; crystalline silica from bricks, cement, and other masonry products; arsenic and chromium from chemically-treated lumber; and some wood

dusts, especially from hardwoods, but also from some softwoods such as Western Red Cedar.

The risk from these exposures varies, depending on how often you do this type of work. To reduce your exposure to these chemicals: work in a well ventilated area and use a properly functioning dust extraction system. When the inhalation of dust cannot be substantially controlled, i.e., kept at or near the ambient (background) level, the operator and any bystanders should wear a respirator approved by NIOSH for the type of dust encountered.

---

## Sander Overview

---

### Intended Use

The ETS sanders are designed for dry sanding and polishing of wood, plastic, metal, composite materials, paint/varnish, filler, and similar materials.

The sander must not be used when wet or damp, or operated in a damp environment for electrical safety reasons. Use this sander only for dry sanding. The tool should not

be altered or used for any other purpose, other than as specified in these operating instructions. Using the tool in contravention to this manual will void your warranty and may lead to injury. The user shall be responsible and liable for damages and accidents resulting from misuse or abuse of this sander.

---

### Technical Specifications

	<b>ETS 125/3</b>	<b>ETS 150/3</b>	<b>ETS 150/5</b>
Power Consumption	200 W	310 W	310 W
Motor Speed	6000-14000 rpm	6000-10500 rpm	6000-10500 rpm
Orbital Stroke	3 mm	3 mm	5 mm
Sanding Pad Diameter	125 mm	125 mm	150 mm
Dust Extraction Port Size	27 mm	27 mm	27 mm
Weight	1.1 kg / 2.4 lbs	1.8 kg / 4.0 lbs	1.8 kg / 4.0 lbs

*These specifications are subject to change without notice.*

## Functional Description



**ETS 125 with Vac**



**ETS 125 with Turbo Bag**



**ETS 150 with Vac**



**ETS 150 with Turbo Bag**

Item	Name or Description	Ref. Page(s)
A	Power Switch/Trigger	12
B	Trigger Lock (ETS 150)	12
C	Speed Control Dial	12
D	Plug-It Power Port	12
E	Sanding Pad	10

Item	Name or Description	Ref. Page(s)
F	Dust Collection Port	11
G	Vacuum Hose	11
H	Dust Bag Holder	11
I	Turbo Dust Bag	11
J	Pad Change Wrench	10

## Sanding Action

The Festool ETS sander is a random orbit sander, which is a form of *dual-action* sander. Dual Action is the broader term which encompasses several subset types of motion which includes gear driven and random orbit types.

Sanding is defined as scratching or abrading a surface. So when we discuss scratches and scratch patterns, the goal is to minimize them or make them less visible to the eye, but they will always be present.

### Dual-Action

Dual-action means that the sanding pad moves in two distinct motions simultaneously. The primary motion is an eccentric orbit—similar to the motion of a bicycle pedal. The center of the sanding disk moves in a small eccentric circle about the center of the sander. The diameter of this orbital path ranges from 2mm to 5mm, depending on the model sander (Refer to “[Technical Specifications](#)” on page 5).

The second motion is the rotation of the disk about the disk’s center. Because the sanding disk is eccentric to the machine center, so is this path of rotation.

The effect of this dual motion is that each point on the sanding pad traces out a geometric shape called a roulette. You may be familiar with this shape from the children’s drawing toy, “Spirograph”. The exact shape of this roulette depends on the ratio between the orbital radius and the radius of the pad rotation. This means that each part of the sanding pad traces out a slightly different shape. This minimizes the visibility of the scratch patterns on the wood because each part of the sanding disk leaves slightly different scratch shapes. Dual action sanders don’t leave fewer scratches, but the scratches are less visible because each one is different.

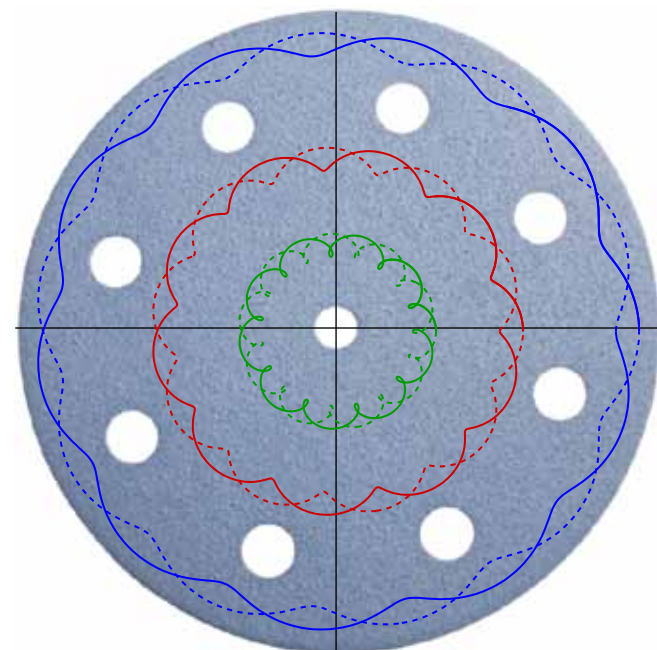
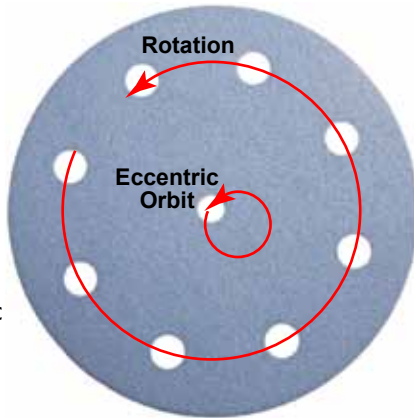

### Random Orbit

This name random orbit is a slight misnomer because it isn’t the eccentric orbit that is random, but the disk rotation that is random. The motion of the sanding pad is still considered dual-action, but the rotational component of the motion is not constrained to follow a strict ratio of the orbits like a gear-driven sander. The disk rotation is permitted to freewheel about the orbit, and this includes even rotating backward at times.

It is this freewheel motion that permits the sander to be both fairly aggressive but to also leave very few visible scratches. Again, it isn’t because there are fewer scratches, but that the scratches are even less visible.

What makes the rotation of the disk somewhat random is friction with the sanding surface. Inertia causes the disk to want to rotate in unison with the orbital motion, but friction with the workpiece tempers this motion, and causes the disk to speed up, slow down, or even turn backward.

You may have noticed that when hand-sanding wood, there is more resistance to sanding across the grain than there is with the grain. The same is true for a random orbit sander. As a result, when the orbital motion is moving across-the-grain, the freewheel rotational motion will resist moving across the grain. The net result will be more scratches being parallel to the wood grain than across the grain.

Unlike a singular orbital motion (orbital sander) or a singular rotational motion (grinder), whose scratch patterns will be circular, a random orbital scratch pattern will be more “V” shaped and in the direction of the wood grain. Because these are less geometric in shape, they are less visible to the eye. The tighter this “V” shape, the less noticeable the scratches will be.

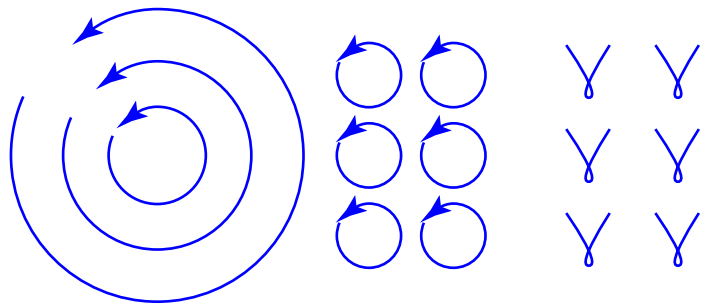

Grinder Scratch Patterns

Orbital Scratch Patterns

Random Orbit Scratch Patterns

### Optimizing Random Orbit

Optimizing the sanding doesn’t remove the number of scratches, it just makes them less visible to the eye. The least visible scratches are those that are not geometric and are in-line with the wood grain. Both of these conditions are optimized by letting the friction between the sanding pad and sanded surface control the rotation of the sanding disk.

Many operators will apply excessive downward pressure to the sander to slow down the freewheel motion of the pad, but this will increase the amount of friction and make the scratches more geometric and more visible. Instead, using a light pressure allows the cross-grain friction to be larger than the in-line friction, and the ideal scratch pattern shown above will be the result.

The best random orbit motion is when the sanding pad has very little pressure, and is permitted to freewheel on its own.

# Anatomy of Sandpaper

The various parts of sandpaper affect its performance. These are shown below and explained in the subsequent sections.

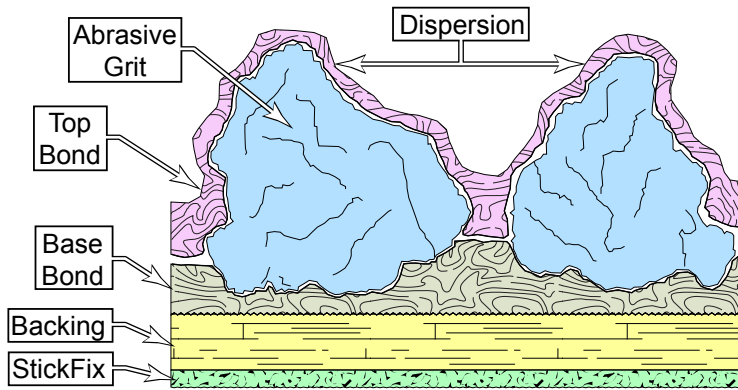

**StickFix** is a short-nap hook and loop system for retaining the sandpaper to the Festool sanding pad. The stiff, short-nap hooks resist heating effects, and therefore last longer.

**Backing** is the primary substrate for the sandpaper. The backing type determines the performance and longevity of the sandpaper. Stiffer backings resist the pressure of the individual grit particles, and is therefore more aggressive in sanding. Softer backings conform to the grit particles more, so the result is shallower scratches from the grit particles.

Paper backing is the most common and economical type, and comes in different thicknesses designated by a letter-weight of b, c, d, or e with the higher the letter, the heavier/stiffer the paper.

Cloth backed disks are the stiffest and intended for extreme usage conditions where long-life is important. The extra durability makes them ideal for a metal working environment, but they may also be used for aggressive sanding in woodworking.

Foam backed disks provide the softest backing for the shallowest scratches. This permits the disk to better contour to the surface being sanded and is ideal for polishing.

**Abrasive** is the material that performs the actual sanding or abrasion. The two most common types of abrasive material are aluminum oxide and silicon carbide, with aluminum oxide being the more common of the two.

**Silicon carbide** is a very hard material with very sharp edges. Because silicon carbide is so hard, it fractures easily, and this exposes new cutting edges to the sanding operation. This keeps the sandpaper very sharp for cutting hard materials, but the grit gets smaller with usage. A side benefit of this is that a coarse grit sandpaper will become a finer grit with use, which is typically desired in the sanding process. Silicon carbide is best suited for finish sanding where reduced sanding pressure reduces how frequently the grit cleaves.

**Aluminum oxide** is almost as hard as silicon carbide, but the crystals are pyramid shaped and do not cleave the edges during use. The edges aren't as sharp, but that is what permits them to last longer. This long life is the reason aluminum oxide is one of the most common abrasive materials.

**Grit** is the size of the abrasive particles. The smaller the grit number, the larger the grit particle size. Larger grit particles will cut deeper into the sanded surface, and therefore, more aggressively. However, the deeper the cut, the deeper the scratches. This is the reason why sanding is performed with

progressively finer grits; to remove the scratches left behind from the coarser grits.

**Dispersion (Coat)** is the spacing between grit particles that coat the substrate. The term "open coat" for example, means that at least 70% of the substrate is open or uncoated. A closed coating means that the substrate is nearly fully coated, and a semi-open coat falls somewhere in between the two. The dispersion is most noticeable in the coarser grits where an open coat results in visible exposure of the substrate (see image below).

A more open dispersion leaves more room for sanding dust (called swarf) to clear the sanding grit to avoid buildup and clogging, but also permits the grit to penetrate deeper into the sanded workpiece, leaving deeper scratches.



**Base Bond and Top Bond** is the material and/or method for adhering the abrasive to the backing material. The grit material is impregnated into the bonding agent to slightly encapsulate the grit material for better adhesion and less fracturing of the grit.

The thickness of the top bond is called the leveling, as it tends to fill in the valleys and level the bond coating. An open leveled top bond is lighter and leaves deeper valleys to permit greater swarf removal.

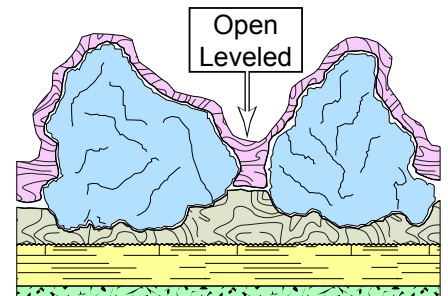

A closed leveled top bond is thicker and fills in the valleys, but provides a stronger bond of the abrasive grit particles. This prevents the grit from breaking loose from the substrate for longer lasting, durable abrasive properties, but may clog faster when sanding materials that generate more swarf.

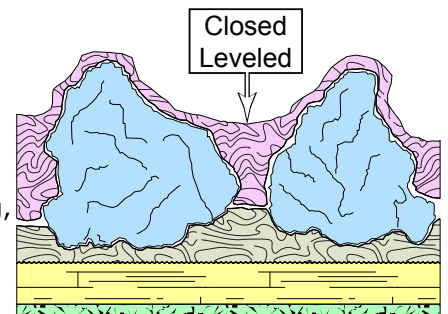



**Non-Woven Fiber**, Vlies (pronounced fleece) is a special abrasive pad of a non-woven fiber impregnated with abrasive into the fiber. The flexible fiber mesh and 3-dimensional abrasive make these ideal for polishing finishes and metal surfaces.











For initial stages of sanding with a coarse grit, the goal is to level the surface. With this comes the trade off between speed versus deeper scratches. The key is to choose the finest of the coarse grits that will provide the leveling in a reasonable amount of time and effort. Choosing too coarse of a grit may actually increase the amount of sanding later to remove excess scratching.

The purpose of fine sanding is the removal of previous scratches. The key here is to sand only up to the finest grit necessary for the desired finish type. The final grit size should be commensurate with the grain or structure size of the material being sanded. Metals, plastics, and finishes; for example, have a very fine structure and may be sanded to a finer grit. Wood, on the other hand, has a relatively large grain structure and should not be sanded beyond a medium grit unless a burnished finish is desired. (Burnishing tends to close the wood pores and reduces the absorption of stains and finishes.)

In summary, you should avoid starting too coarse or finishing too fine for the particular material or surface type.

### Choosing the Appropriate Grit

Selecting the best sanding grit for a task is fairly subjective and depends on the task. The adage of working progressively up through the grits is based on the principle of each finer grit removing the scratches that the coarser grit leaves behind.

Best Sandpaper for the Task			
Name	Type	Range	Description
<b>RUBIN</b> 	<ul style="list-style-type: none"> <li>▶ Aluminum Oxide</li> <li>▶ e-Wt Paper</li> <li>▶ Synthetic Resin</li> <li>▶ Closed-coat</li> </ul>	P40-P220	The heavy weight paper backing and strong top bond make this sandpaper very good for long lasting use on bare wood, metal, and auto body fillers.
<b>GRANAT</b> 	<ul style="list-style-type: none"> <li>▶ Aluminum Oxide</li> <li>▶ Synthetic Resin</li> <li>▶ Closed-coat</li> </ul>	P40-P1500	The non-wax steared coating and lighter paper weight make this a very good universal sandpaper for finished and unfinished wood, metal, plastic, solid surface, and composite materials. The high density closed coat grit is more uniform for reduced scratches.
<b>BRILLIANT</b> 	<ul style="list-style-type: none"> <li>▶ Aluminum Oxide</li> <li>▶ Synthetic Resin</li> <li>▶ Closed-coat</li> </ul>	P40-P400	The lighter weight paper and thinner top bond results in shallower scratches for good sanding results in harder woods, finishes, and paints. The open-leveled top bond and anti-static coating loads less when sanding finishes.
<b>SAPHIR</b> 	<ul style="list-style-type: none"> <li>▶ Aluminum Oxide</li> <li>▶ Cloth-backing</li> <li>▶ Semi-close Coat</li> <li>▶ Closed-leveled</li> </ul>	P24-P100	The cloth-backing, semi-closed coating, and closed-leveled bond make these disks very durable workhorses for sanding and leveling on hard wood, metal, fiberglass, and reinforced plastics.
<b>CRISTAL</b> 	<ul style="list-style-type: none"> <li>▶ Aluminum Oxide</li> <li>▶ Phenolic Resin</li> <li>▶ Open-coat</li> </ul>	P40-P120	The broad open-coat dispersion of this disk makes it ideal for aggressive sanding without loading on clog-prone materials, such as paint stripping or high-resin woods.
<b>TITAN</b> 	<ul style="list-style-type: none"> <li>▶ Aluminum Oxide</li> <li>▶ Synthetic Resin</li> <li>▶ Latex Base Bond</li> <li>▶ Semi-close Coat</li> </ul>	P40-P3000	The latex base bond provides greater flexibility of the grit coating, which makes Titan idea for polishing tasks on solid surface, plastics, and finishes. The semi-closed coat and open-leveled top bond result in finer sanding with fewer scratches. However, with the stearate coating, it is not recommended for water borne finishes.
<b>PLATIN</b> 	<ul style="list-style-type: none"> <li>▶ Silicon Carbide</li> <li>▶ Synthetic Resin</li> <li>▶ Open Coated</li> <li>▶ Foam</li> </ul>	S400-S4000	The tight woven grit base and foam backing makes Platin ideal for a high gloss surface in plastic, solid surface, and finishes. The permeable foam and fiber results in consistent dust extraction across the whole disk and cooler surface temperatures.
<b>VLIES</b> 	<ul style="list-style-type: none"> <li>▶ Al-Ox or Si-Carb</li> <li>▶ Synthetic Resin</li> <li>▶ Stearate Si-C</li> </ul>	A120-A800	The elastic fiber mat with impregnated grit makes Vlies ideal for deep pore cleaning of woods and scouring or de-rusting of metals.

# Setup

## Changing Sanding Pads

Each model sander may be used with a variety of sanding pad options. It may also be necessary to change sanding pads for different sanding purposes or when they become worn.



**CAUTION!** Do not use a sanding pad if it no longer holds the sanding disk in place. Using a worn pad can result in the sanding disk to fly off the pad and cause injury. Sanding pads are considered a wear item and should be replaced when the StickFix hook-&-loop fibers cannot firmly hold the sanding disk.



**NOTE:** Excessive heat from sanding will cause the sanding pads to wear faster. To maximize your pad life, avoid operations that generate excessive friction and heat, such as sanding stationary on a sharp edge or applying too much pressure while sanding.

## Choosing the Correct Sanding Pad

Sanding pads come in different grades of hardness/softness for improved performance for different sanding tasks. The hardness or softness of the sanding pad determines how much the sanding pad conforms to the surface being sanded.

A harder sanding pad is best for course sanding on flat surfaces. The firmer pad resists creating a wavy surface where there are softer and harder portions of the wood fiber. This is especially important with woods that have a wide spacing in their annular growth rings or significant differences in the density of the wood fiber between rings.

A slightly softer sanding pad is best used for progressively finer sanding of the workpiece. This permits the pad to slightly conform to the surface to ensure previous grit sanding marks are removed, but is less prone to creating a wavy surface because the grit is less aggressive.

Similarly, a very soft sanding pad is best used for fine sanding or sanding of finishes. Having greater conformance to the very small waves in the surface is desired, and with the high grit abrasive, risk of creating deeper waves is less likely.

## Removing/Installing the Pad

1. Unplug the sander for safety.
2. For the ETS 125, remove the four, T15 Torx screws, and remove the pad.



3. For the ETS 150, using the 5mm hex key stored in the base, remove the socket head cap screw from the center of the pad and remove the pad.

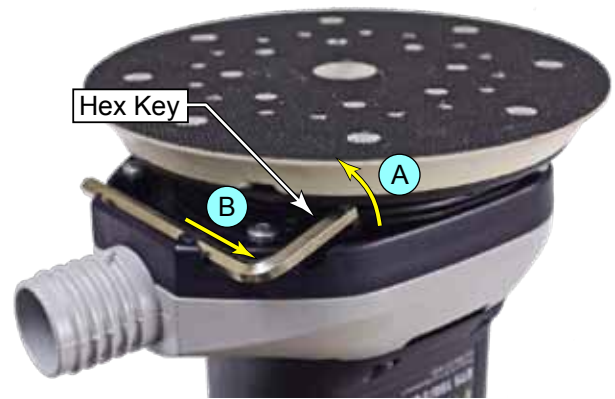

- During replacement, make sure to align the flats on the pad and spindle.



## Changing Sandpaper

The sandpaper is held in place with a hook & loop system, and can be changed by simply pulling off the old disk and pressing on a new one. However, for the integral dust collection, make sure to align the holes in the sandpaper with the dust extraction inlets in the sanding pad.



## Using the Turbo Collection Bag

The ETS sander has an integral vacuum blower for self contained dust extraction with a turbo collection bag. The disposable collection bags are held to the sander with the removable bag holder.

To install the bag holder, slide it over the dust port of the sander and past the alignment pin, and then tighten the clamping screw.

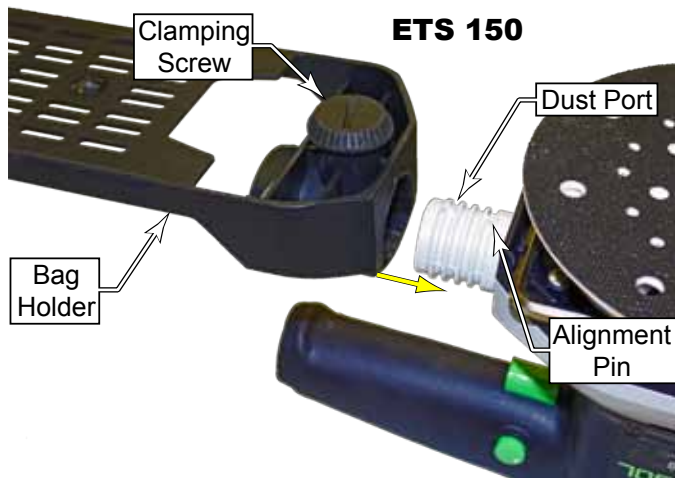
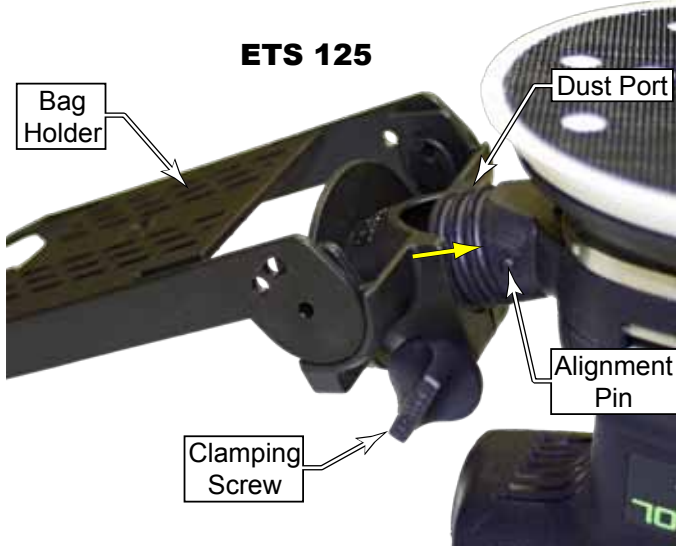

To install the collection bag on the ETS 125 holder, slide the rear flange over the retaining tab, and then slide the bag flange over the bag port.

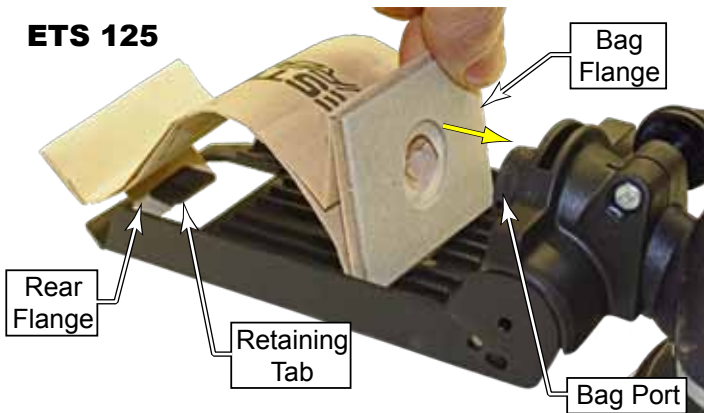

To install the collection bag on the ETS 150 holder, slide the rear flange over the retaining tab, and tilt the rear flange to the vertical position.

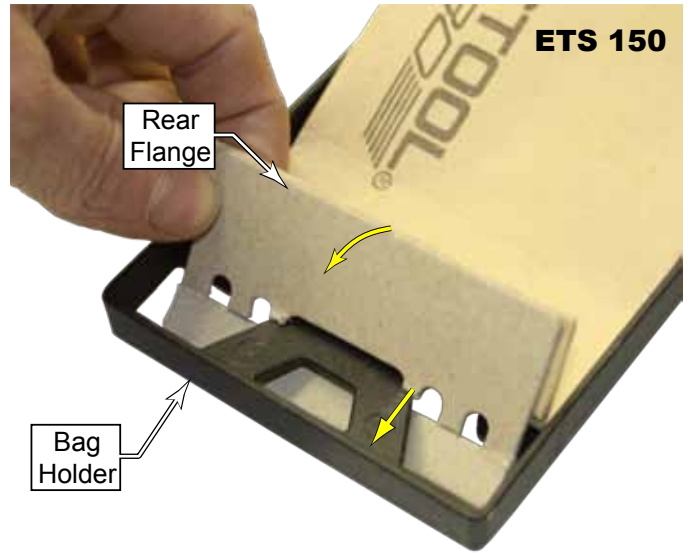

Then slide the bag flange over the bag port until it seats against the front of the bag holder.

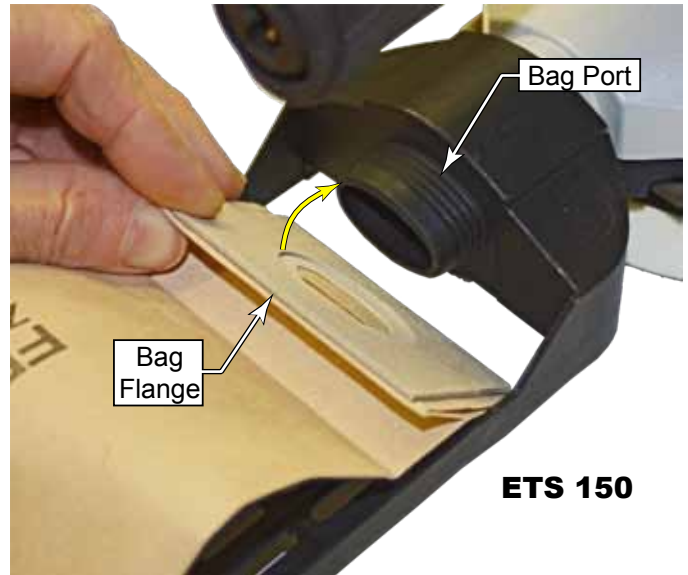

## Connecting a Dust Extractor

The dust port on the back of the sander connects to a Festool 27mm vacuum hose. To connect the hose, rock it back and forth over the ribs while pressing inward.

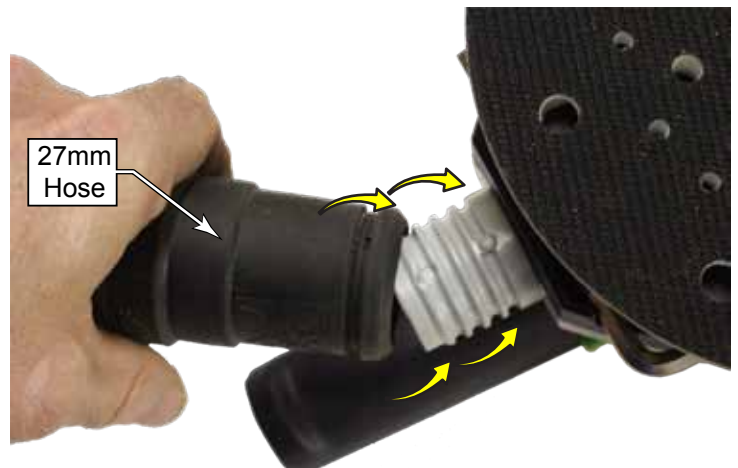

## Connecting the Plug-It Power Cord

The sander comes equipped with a removable Plug-It power cord. The cord can be removed for easier storage of the tool. To install the power cord, insert the cord into the inlet (port) on the tool with the key and keyway aligned, and twist the locking ring ¼-turn until it clicks. Reverse the procedure to remove the cord.

**NOTICE:** Make sure to fully tighten the plug-it cord a full quarter-turn until it clicks. If the plug is not fully locked, the socket and cord can overheat and be damaged.

**NOTE:** The 18 gauge plug-it cord is interchangeable with other tools that use the same size cord, but it cannot be used with larger tools, such as routers and saws. The plug has an extra key to prevent it from being used on a larger tool that would otherwise damage the cord. Larger cords may be used with smaller tools, but not the reverse.

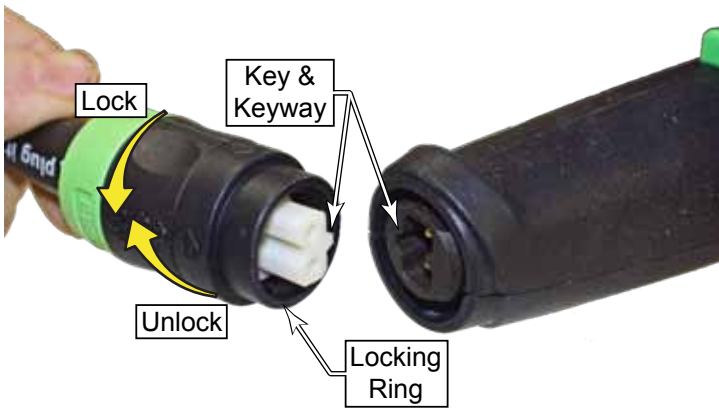

## Setting the Variable Speed

The speed of the sander is adjustable with the speed control dial. Most operations are best performed at full speed, but a lower speed can sometimes improve control or reduce aggressiveness for finer operations, such as polishing or buffing. The speed may be adjusted with the motor either on or off. The slowest speed is 1 and the highest speed is 6.



## Turning on the Sander

For best control and sanding results, the sander should be placed on the sanding surface with no downward pressure before turning it on, and lifted from the surface before turning it off. The ETS sanders have soft-start circuitry, so there will be a slight delay before the sander reaches the set motor speed.

To turn on the ETS 150, pull up on the power trigger, and release to turn the sander off. To lock the trigger in the on position, press in on the trigger lock and then release the trigger. Pulling up on the trigger again will release the trigger lock.

To turn on the ETS 125 sander, toggle the power switch to the on position. To turn the sander off, toggle the power switch to the off position.



# Operation

Aside from installing sandpaper, your ETS sander is ready to use right out of the box. There is no special setup, adjustment, or break-in procedure required before using your sander. However, new users may want to practice with the sander to become familiar with its operation, function, and even the best way to hold the sander.

Sanding is frequently considered one of the most important

stages of any type of project because it is often the first stage of the finishing phase. Even given its great importance, the nuances of sanding are often overlooked, and it is viewed as more of a chore than a productive aspect of the overall project. Discovering the optimal nuances of your sander will help you get the most out of your sander, but may take some practice and learning.

## Pad Brake

Pad brakes reduce the freewheeling motion of the sanding pad when the sander is not in contact with the workpiece. This prevents gouging of the wood when the sander first contacts the surface. During sanding, however, the pad brake should have a minimal impact on pad rotation.

A new sander will contain a thin lubricating film between the sanding pad and the pad brake. This prevents the pad brake from being too aggressive in reducing the motion of the

sanding pad when the pad and brake are new and dust-free. As the sander is used, buildup of fine dust particles act as an interface lubricant.

Although not required for normal operation, if you feel the pad brake is not slipping enough during normal sanding, you may wish to apply a lubricant, such as paste wax, between the pad and brake.

## Using Dust Extraction

Using dust extraction on an ETS sander isn't just a matter of keeping the work area clean or protecting your health; which of course is very important. The sander itself is specifically designed to perform best when used with either the on-board Turbo collection bag or with a workshop vacuum.

Sanding wouldn't be very effective if a layer of sanding dust was permitted to accumulate between the sanding pad and the sanded surface. Festool sanders incorporate *Airstream* technology to help get the sanding dust away from the sanding surface as efficiently as possible. With traditional sanding pads, dust accumulates at the center of the disk because it can't get drawn out by the vacuum. *Airstream* technology creates airflow from the center of the pad radially outward to the dust extraction holes (as well as the normal airflow from the perimeter). This keeps the dust clear and allows the sanding grit to work on the sanding surface.

can suck the sander tight to the workpiece, which reduces sanding quality and diminishes controllability of the sander.

For best results, the power of the vacuum should be reduced below maximum. A sign that the vacuum is too strong is a lack of controllability, with excessive jumping and jitter in the movement of the sander across the workpiece. Having the vacuum set too high will also increase the depth of sanding scratches, and make them more difficult to remove through the higher sanding grits. The optimal vacuum power will vary depending on the size of the sander and even the coarseness of the sandpaper, with finer grits needing less power.

1. To use the dust extraction system, slide the vacuum hose over the dust collection port as described on [page 13](#).
2. Plug the sander into the electrical receptacle on the front of the dust extractor, and turn the power switch to "Auto".
  - ▶ When the power switch is in the manual or off position, the electrical outlet will not have any power.
3. Turn the speed control dial counterclockwise to reduce the power of the vacuum.

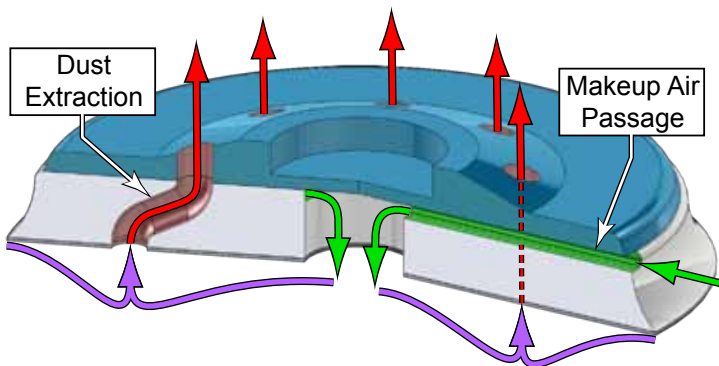

With HEPA filtration, auto-start, and variable speed, Festool dust extractors are ideally suited for use with ETS sanders. The variable speed is of particular importance because it permits adjusting the power of the vacuum for the optimal performance of the sander. Too high of a vacuum pressure

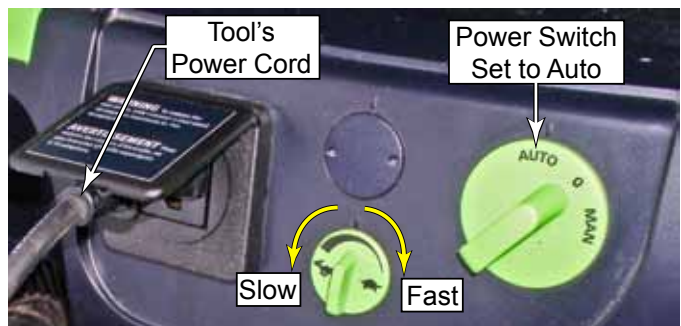

## Choosing Hand Positions

While it may sound trivial on the face of it, how you hold the sander plays a pivotal role in the optimal performance of the sander. Balance, control, and comfort are the keys in deciding what hand positions work best for you. It is recommended to spend some time practicing and refining your handhold positions to suit your needs. They will vary from user to user, but the information below presents the most common starting point for many users.

The ETS 125 is a palm-grip sander, and is typically held with one hand on the top of the sander. Choose a hand position that is comfortable and well balanced. If the sander motion feels jittery, it is a sign that it is not being held balanced and level with the sanded surface.

The ETS 150 is a combination pistol-grip and palm-grip sander. It can be held one handed or two, or from the pistol grip, palm grip, or both. Regardless which type of grip is used, it should be balanced with respect to the pressure on the sanding pad.

When experimenting with different hand grips, use varying sandpaper grits. The goal is to hold the sander in such a way that balance and control are achieved, which results in the smoothest motion of the sander as you move it about the workpiece. Here are some signs that your grip on the sander is not balanced:

- ▶ Uneven resistance to movement: If the sander resists more in one direction than the opposite direction, it is a sign that you are slightly tilting the sander.
- ▶ If you experience excessive jumping and jitter, it means your grip is not balanced, you're moving too fast, and you are applying too much down force to the sander.



## Working With Sanding Grits

Generally speaking, the sanding process begins with the coarser grits and progresses up to the finer grits. However, not all sanding tasks are the same. So choosing which grits to use will vary depending on the task. The adage of progressing through the grits holds true for nearly all sanding, but where to begin and where to end isn't always clear.

While the coarsest grits provide rapid material removal and leveling, it isn't always desired to begin sanding with the coarsest grit available. Avoid starting with too coarse of a grit. For example, when working with pre-planed lumber, there should be little need to use a coarser grit than 120 unless there is the need for joint-leveling. Even with joint-leveling, only a slightly coarser grit may be called for, with coarser grits reserved for joint leveling of wider panels.

Similarly, the highest grit chosen should be commensurate with the type of material and surface finish desired. The grit size should be consistent with the grain size of the material. Very high grits should be used for achieving a high gloss surface on paints, finishes, and plastics. However, because the grain size of wood is much larger than man-made materials, the highest (unfinished) sanding grit should be much more limited.

When sanding bare wood in preparation for applying most surface-build finishes, a sanding grit of approximately 220 grit should be considered the maximum, or even slightly lower for very high-build finishes. On the other hand, for non-build finishes or when the bare wood is the final finish, then higher grits may be called for. Using too high of a grit will tend to burnish the wood. With some non-build finishes or for bare wood, this is desired. However, for most surface-build finishes, burnishing can hinder finish penetration of the surface.

For colorants, and especially pigmented stains, the higher the bare wood sanding grit, the less the colorant will penetrate the wood. In some cases this can even lead to a loss of grain definition in the final finish. However, this can also be used to an advantage for controlling the intensity of a colorant, by using a coarser grit for a darker intensity and a higher grit for a lighter intensity.

The purpose of progressing through the grits from coarse to fine is so that each successive grit is aggressive enough to remove enough material to remove the scratches of the previous grit, while only leaving smaller scratches itself. This is most apparent in the coarser grits where the grit scratches are deeper.

# Sanding Techniques

## Establishing Optimal Sanding Pressure

The amount of downward force applied to the sander will have a varying impact on how aggressive the sander will perform, but also on the controllability and finish level too. More downward force will make the sander operate more aggressively, but it will also tend to make the sander more difficult to control and reduce the quality of the finish. The general rule for any rotational type sander is to keep minimal downward force on the sander and let the sander to the work on its own.

The primary sign that you are applying too much down pressure is that the sander will lurch and jitter as it moves across the sanding surface. When this happens, reduce the sanding pressure, which even includes lifting the sander a

little bit when necessary.

With random orbit sanders, anything that diminishes the “randomness” of the pad rotation increases the occurrence of visible scratches. Initial intuition may suggest that slowing down the pad rotation is good, but the opposite is true. If the pad is not freely spinning, then the motion is not random, and too much down force is being applied to the sander.



**NOTE:** The effect of the vacuum created below the sanding pad from the dust extractor will add some downward force to the sander. It is important to reduce the power of the dust extractor so it is not applying too much down-force on the sander.

## Sanding Pattern and Movement

One key to achieving a quality sanded finish is to establish an effective and smooth sanding pattern for moving the sander across the workpiece. Different patterns and speeds of motion will be optimal for different material types and even different grits of sand paper.

Because the sanding pad is moving in a clockwise dual motion, a general clockwise sanding pattern produces the least resistance to movement, and therefore, the smoothest pattern. As much as possible, make your motions and direction changes in a general clockwise direction.

For homogenous materials that do not have a discernible grain direction, such as metals, plastics, solid surface, and finishes; a circular pattern may be best. These types of patterns do not have a stopping or sharp transition point where the direction of the sander is abruptly changed.

For materials with an inherent grain structure such as wood and even some plastics, the sander motion should be kept generally in-line with the grain as much as reasonably possible. This leads to a linear back and forth motion, but the transitions for changing direction should be as smooth as possible without an abrupt stop/start.

### Example, Solid Surface Joint Leveling:

Solid surface material has a non-oriented grain structure. It is therefore best to sand in a generally circular pattern. For initial leveling, sanding emphasis should be applied to the higher of the two surfaces, but not to the complete exclusion of both surfaces. This calls for an oval pattern overlapping onto the lower surface, yet focused on the upper surface.



As the joint becomes more level, the pattern should switch to perpendicular to the joint in tight overlapping loops.



### Example, Wood Panel Joint Leveling:

In a similar fashion, initial leveling should focus on the higher surface, but not to the exclusion of the lower surface. Some overlap across the joint is required to avoid the likelihood of creating a slight depression on the high surface just inside the joint. As leveling progresses, the sanding pattern should become more balanced across the two pieces.

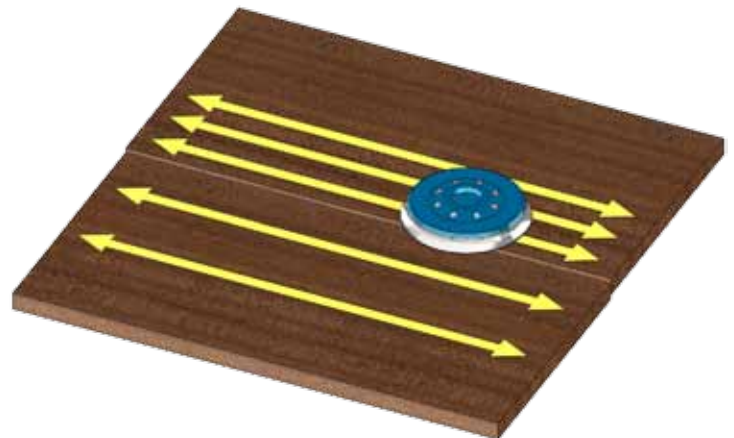

### Example, Faceframe Leveling:

While the temptation may be to focus sanding directly over a frame's joint, this should be avoided. To reduce the chance of a depression at the corner, a general L-shaped pattern should be used extending well beyond the joint. For more emphasis at the joint, a mixture of both short and long strokes should be used, but never just stationary over the joint.

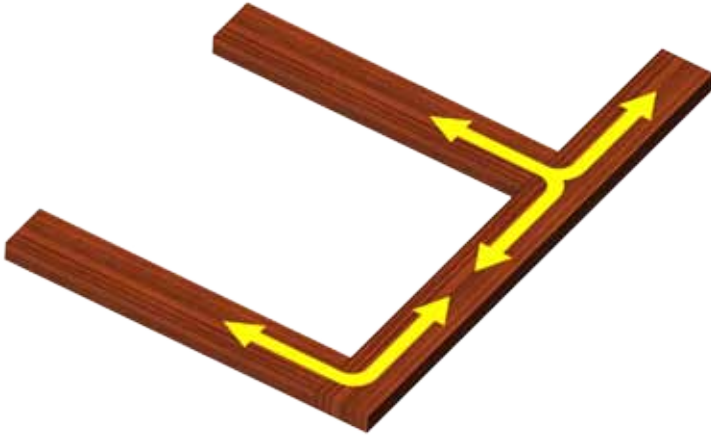

Once the joints are leveled, the entire frame should be sanded, but this too should have a pattern. While not as critical, the general approach is to sand those frame members which are captive between other frame members first. In other words, sand the horizontal rails first, followed by the vertical stiles. This results in your longer sanding strokes covering over the previous transitions from the end of the short strokes.

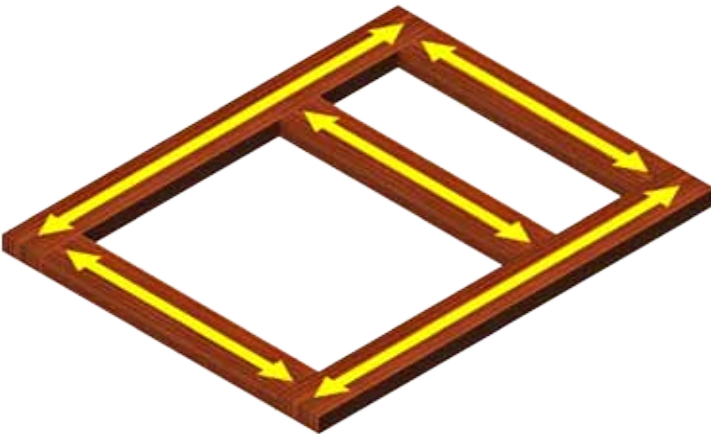

### Example, Frame to Carcase Leveling:

Leveling the joint between a solid wood frame and a plywood veneer carcase is one of the most precarious sanding operations due to the likelihood of sanding through the thin veneer. The key is to evenly remove enough of the solid wood frame without sanding into the veneer.

While the temptation may be to sand the frame with only the edge of the sanding pad, this will invariably result in a slight bevel on the frame. Instead, keep the center of the pad centered over the frame, but held as perfectly parallel to the surface as possible. Sand the frame flush, and then begin working out into the veneer surface. Here are some tips to safely achieving flush joints:

- ▶ Using a soft, wide-lead pencil, scribble across the veneer near the joint. As long as the pencil lines remain, you will not be sanding through the veneer.
- ▶ Use the firmest sanding pad available to avoid rounding the edge of the frame.
- ▶ Avoid using too coarse of a disk, as the veneer can be damaged too quickly if you tilt the sander.
- ▶ Operate the sander with authority and firm pressure to maintain maximum control, but reduce the pressure as the joint gets closer to flush.
- ▶ Avoid the tendency to tilt the sander away from the veneer, as this will create a bevel on the frame.
- ▶ As the joint gets close to flush, expand your strokes to include more of the veneer surface, and continue sanding until the pencil marks are gone.

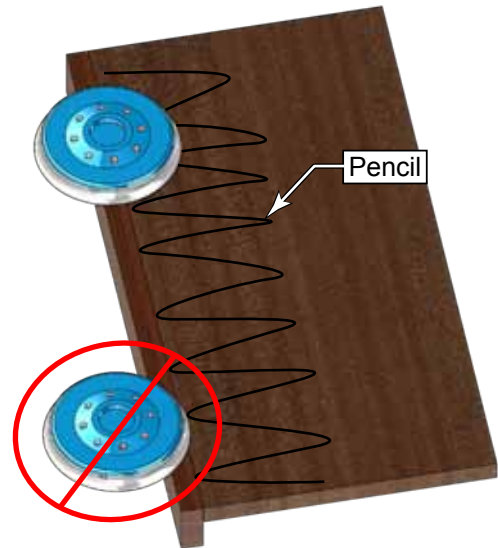



# Maintenance and Adjustment



**WARNING!** To reduce the risk of electrocution or other personal injury, always unplug the tool from the power supply outlet before performing any maintenance or repair work on the tool.



**CAUTION!** Any maintenance or repair work that requires opening of the motor or gear housing should be carried out only by an authorized Customer Service Center (see your dealer for information on locating a service center).



**NOTICE:** Do not use compressed air to clean the motor housing of the tool, as you could inject foreign objects into the motor through the ventilation openings.



**NOTICE:** Certain cleaning agents and solvents are harmful to plastic parts. Some of these include, but are not limited to: Gasoline, Acetone, Methyl Ethyl Ketone (MEK), Carbonyl Chloride, cleaning solutions containing Chlorine, Ammonia, and household cleaners containing Ammonia.

## Routine Maintenance

Dust and debris from some materials can be extremely abrasive and cause components within the sander to wear prematurely. It is important to keep moving parts cleared of abrasive dusts.

▶ As a general rule, keep the sander clean of all dust and

debris. Even soft-wood dust can be abrasive over time.

- ▶ Examine all moving parts for dust and debris.
- ▶ Sanding pads are considered a wear item and will need to be replaced periodically. Replace the pad when it no longer holds sanding disks in place.

## Troubleshooting

Symptom	Possible Causes
Motor does not start	<ul style="list-style-type: none"> <li>▶ Check that the cord is properly plugged into an outlet.</li> <li>▶ Make sure the Plug-it connector is properly inserted and fully tightened.</li> <li>▶ Make sure the outlet has power. Check the circuit breaker or try another outlet.</li> <li>▶ If used with a Festool dust extractor, make sure the selector switch is pointing to "Auto". The auxiliary outlet on the dust extractor has power only when the selector is at Auto.</li> <li>▶ Inspect the power cord (including extension cords) for damage or missing prongs.</li> <li>▶ The motor brushes may have worn and need replacement.</li> <li>▶ Please note that the power switch is a sealed pneumatically actuated switch that is not prone to dust ingestion. Do not attempt to open the switch.</li> </ul>
Sander runs sporadically or loses power	<ul style="list-style-type: none"> <li>▶ Make sure the Plug-it cord is properly tightened. Inspect the plug and tool power inlet for signs of overheating. If signs of overheating are present, discontinue use and have the tool serviced. If the Plug-it cord shows signs of overheating, do not use the cord for other tools, as it can damage the inlet of the other tool.</li> </ul>
Sanding disk doesn't stick or flies off during sanding	<ul style="list-style-type: none"> <li>▶ Make sure the disk is firmly pressed onto the pad.</li> <li>▶ To make sure it isn't a defective disk, try using a different disk.</li> <li>▶ Make sure the bottom of the pad is clean and free of debris.</li> <li>▶ The sanding pad is a wear item and may need replacement. Sanding generates heat, and heat will degrade the Stickfix hooks on the sanding pad. Avoid operations that generate excessive heat, such as holding the sander motionless on sharp edges.</li> </ul>
Deep scratches in finish sanding	<ul style="list-style-type: none"> <li>▶ The most likely cause is that scratches from a coarse grit paper are too deep for the current/final grit paper. Make sure you don't skip a grit in progression.</li> <li>▶ Rework the finish with a grit appropriate to remove the scratches and progress to finish grit.</li> <li>▶ Avoid beginning with too coarse of a grit for the need. Begin sanding with a grit only coarse enough to meet the smoothing and leveling needs of the project.</li> </ul>
Excessive swirl marks	<ul style="list-style-type: none"> <li>▶ Make sure the dust collection vacuum is set for reduced power. Too much vacuum will apply too much pressure to the sanding surface.</li> <li>▶ Reduce your sanding pressure. Too much sanding force reduces the freewheel motion of the sanding pad, which results in sanding swirls.</li> <li>▶ With the sander turned off, inspect the freewheel motion of the sanding pad. If the freewheel seems too stiff, apply a thin lubricant such as paste wax between the pad brake and sanding pad.</li> </ul>
Sander jumps or is hard to control	<ul style="list-style-type: none"> <li>▶ Make sure you are holding the sander level on the work surface. Tilting the sander or even applying uneven down-force can cause it to jump.</li> <li>▶ Reduce sanding pressure and make sure the dust collection vacuum is running at reduced power.</li> <li>▶ Inspect the sanding pad for proper installation. A loose or misaligned sanding pad can result in runout in the orbital motion.</li> </ul>

# Motor Brush Replacement

Motor brushes provide electricity to the spinning motor armature, and will wear over time. The brushes are designed to disconnect power to the motor when they have

worn beyond their usable life. If your sander stops working, it is likely that the brushes have worn and need replacement. Contact Festool for replacement brushes.

## ETS 125 Motor Brushes



**WARNING!** To avoid the risk of electrical shock, make sure the sander is unplugged from power.

1. Unplug the sander from power.
2. Remove the 2 T15 Torx screws that secure the motor cover, and remove the cover.



3. Tilt the rear brush out of its socket and then slide it back away from the motor to remove it.

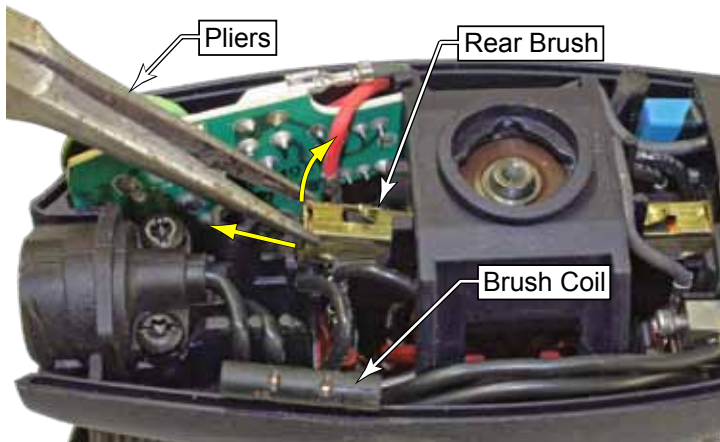

4. If the new brushes come with new brush holders, remove the brush holder by disconnecting the terminal from the motor winding. Otherwise you may skip this step.

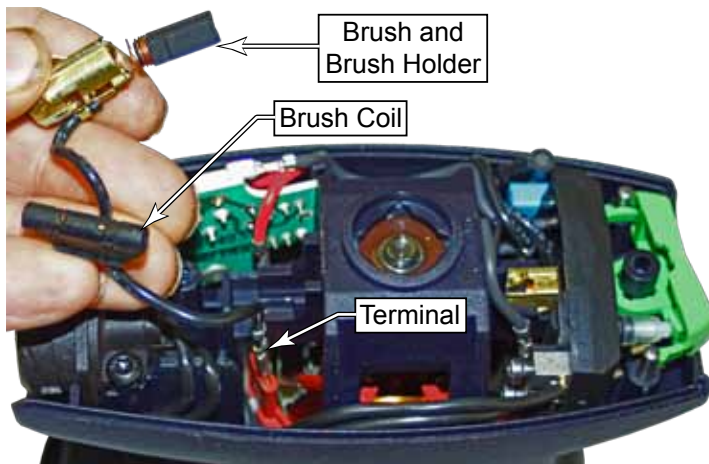

5. Insert the new brush into the brush holder.

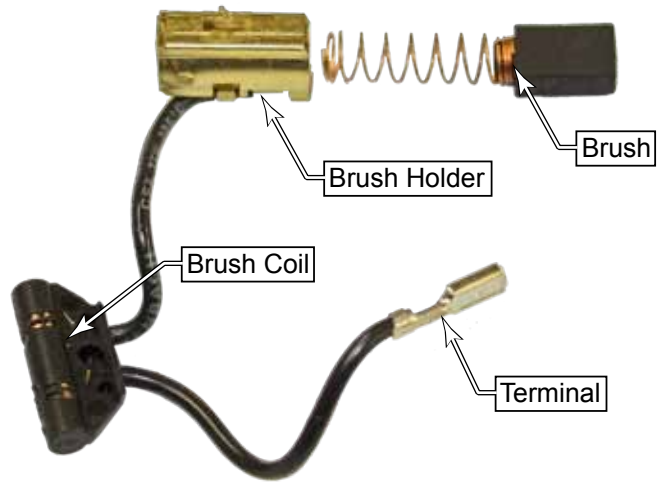

6. Reconnect the wire terminal if it was previously disconnected.
7. Loosely route the wires and the coil approximately as shown.
8. While pressing the brush into the brush holder, insert the brush holder into the motor, tilted downward as shown.
9. Continue pressing the brush holder toward the motor until it can rest into its retaining pocket.
10. Tuck the coil in neatly along the sander housing, and make sure the terminal and coil wires will not be pinched when the cover is replaced.

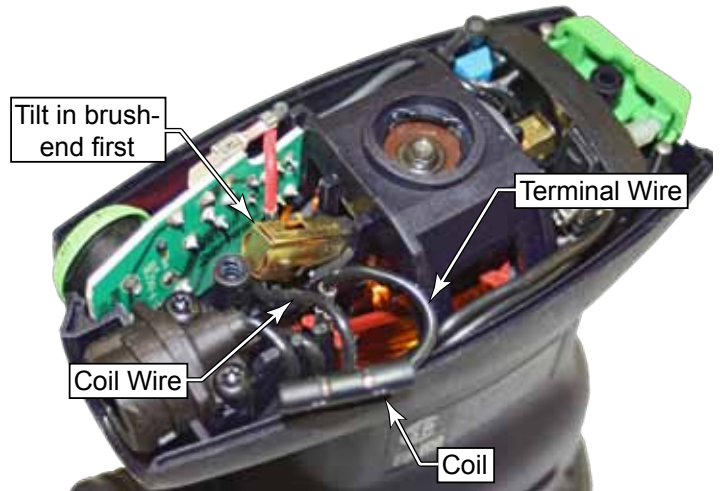

11. With the power switch in the off position, lift the switch rocker straight up off the pivot post.
12. Carefully lift the switch module out of the housing. Take care to not let any components snag on wires as you lift it out.

16. Make sure the brush coil and the brush wires are tucked in neatly and won't be pinched when the motor is replaced.
17. Reconnect the switch module wires if they were previously disconnected.
18. Carefully reinsert the switch module by fitting the pins into their sockets.

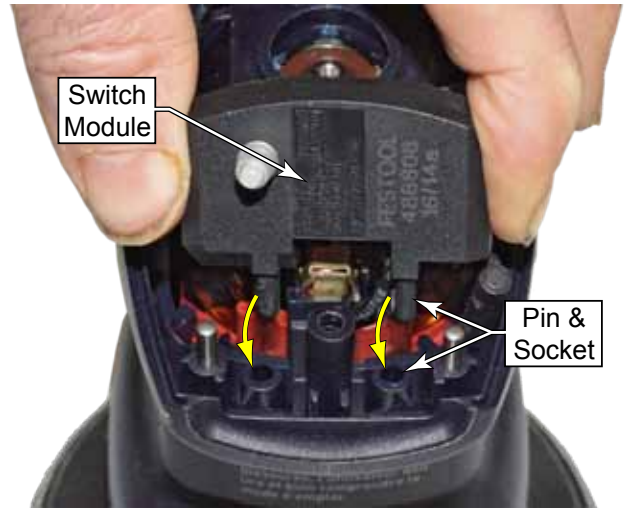
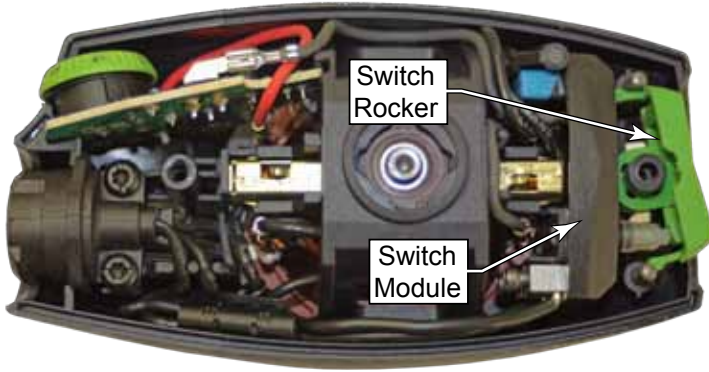

13. Move the switch module out of the way. If desired, remove the control board and motor winding wires.

19. Replace the switch rocker.
20. As you replace the motor cover, make sure no wires are pinched between the motor housing and the cover. Refer to the image below for final wiring, coil, and component placement.

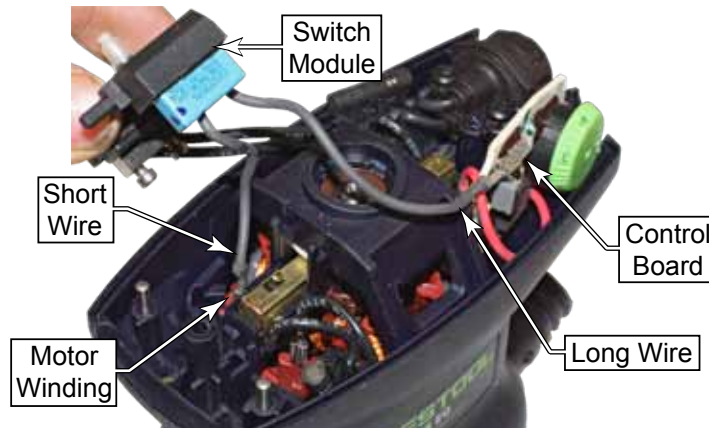

14. Tilt the front brush out of its socket and then slide it back away from the motor to remove it.
15. Install the new brush into the brush holder in the same manner you did for the rear brush, and reinstall the brush holder.

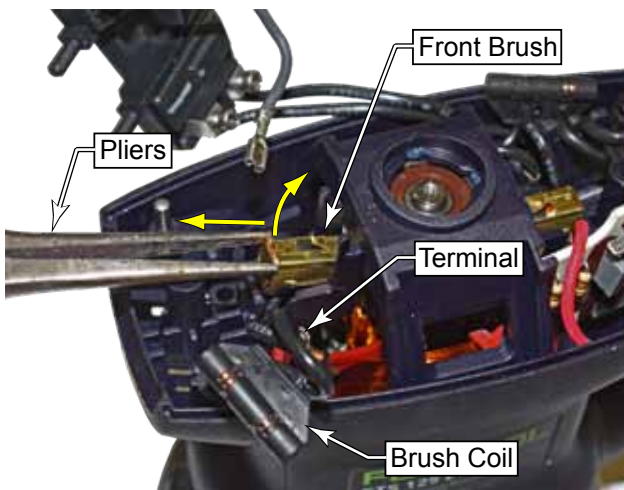

## ETS 150 Motor Brushes



**WARNING!** To avoid the risk of electrical shock, make sure the sander is unplugged from power.

1. Unplug the sander from power.
2. Remove the 4 T15 Torx screws that secure the motor cover, and remove the cover.

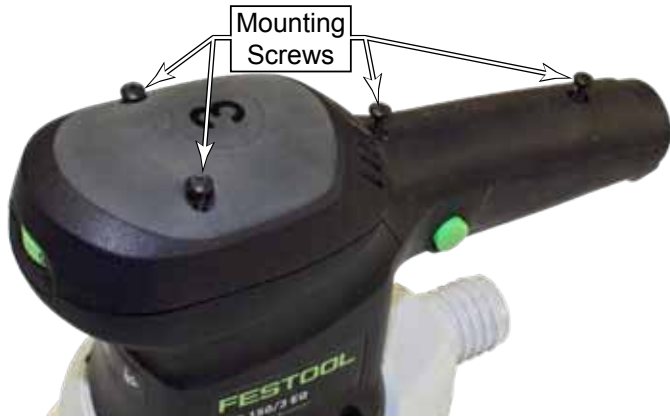

3. Before beginning, make note of the control module wire routing for later replacement.
4. Carefully lift the control module straight up, while simultaneously freeing the wires from their clips. Move the module to the side to access the brushes.

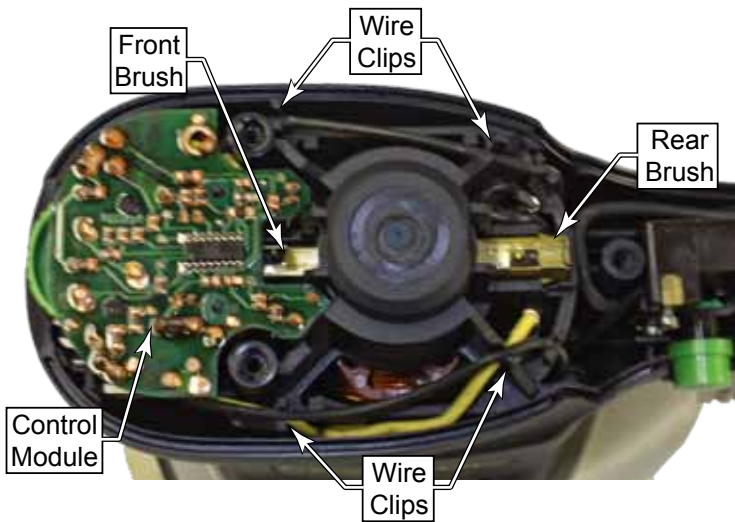

5. Tilt the rear brush out of its socket and then slide it back away from the motor to remove it.
6. Disconnect the wire terminal from the motor winding.

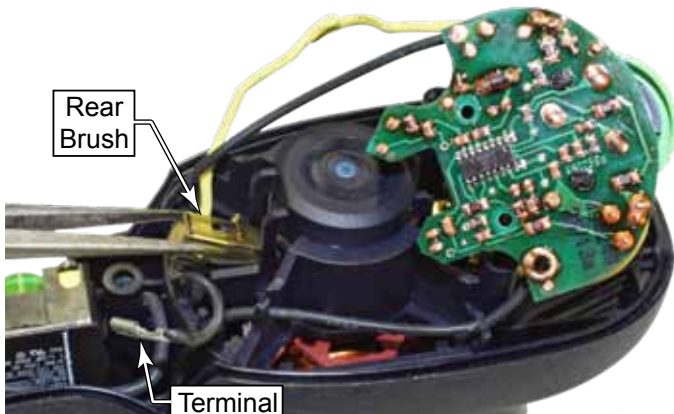

7. Tilt the front brush out of its socket and then slide it back away from the motor to remove it.
8. Disconnect the wire terminal from the motor winding.

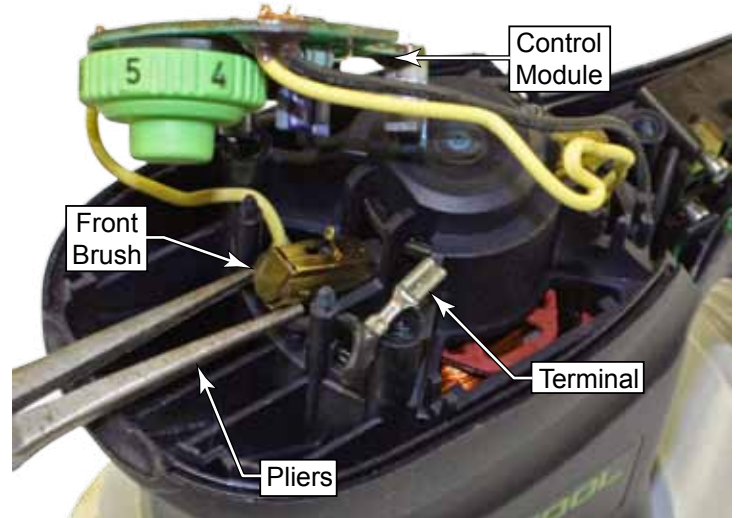

9. Remove the brushes from their brush holders.
10. While inserting the new brushes in their brush holders, compress the spring so the contact plate remains straight. Fully compress the brush into the holder to help ensure that the contact plate remains straight and is resting against the rear wall of the holder.

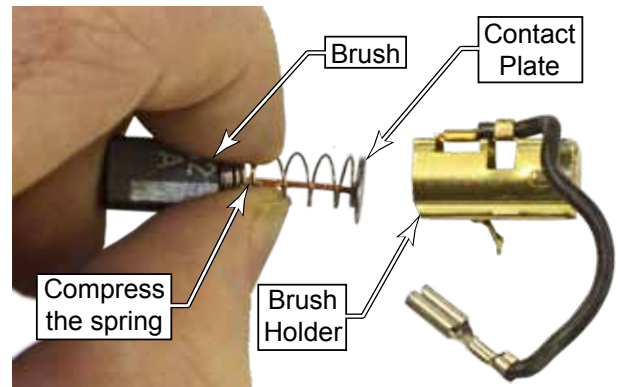

11. Insert the brush holder into the motor with the brush tilted downward toward the motor commutator.
12. Continue pressing the brush holder toward the motor until it can rest into its retaining pocket.
13. Reconnect the brush wires to their terminals.
14. Carefully replace the control module over the alignment pins in the motor housing. Tuck in all wires.

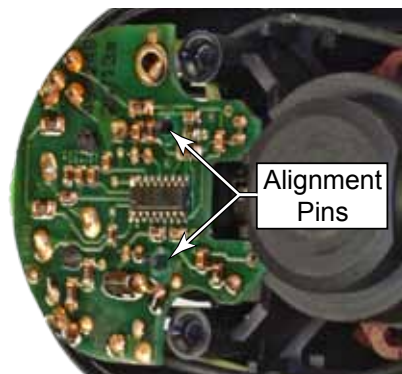



# FESTOOL®

Tools for the toughest demands

**Festool USA**

400 N. Enterprise Blvd

Lebanon, IN 46052

[www.festoolusa.com](http://www.festoolusa.com)

Service Questions:

800-554-8741

Application Questions:

888-337-8600