



Operating Instructions and Parts Manual 8-inch Bench Grinder

Model JWBG-8



Model 726100 shown

For models with serial no. 15100001 and higher.

JET
427 New Sanford Road
LaVergne, Tennessee 37086
Ph.: 800-274-6848
www.jettools.com

Part No. M-726100
Revision C 07/2015
ECR TW0137
Copyright © 2015 JET

1.0 Warranty and Service

JET warrants every product it sells against manufacturers' defects. If one of our tools needs service or repair, please contact Technical Service by calling 1-800-274-6846, 8AM to 5PM CST, Monday through Friday.

Warranty Period

The general warranty lasts for the time period specified in the literature included with your product or on the official JET branded website.

- JET products carry a limited warranty which varies in duration based upon the product. (See chart below)
- Accessories carry a limited warranty of one year from the date of receipt.
- Consumable items are defined as expendable parts or accessories expected to become inoperable within a reasonable amount of use and are covered by a 90 day limited warranty against manufacturer's defects.

Who is Covered

This warranty covers only the initial purchaser of the product from the date of delivery.

What is Covered

This warranty covers any defects in workmanship or materials subject to the limitations stated below. This warranty does not cover failures due directly or indirectly to misuse, abuse, negligence or accidents, normal wear-and-tear, improper repair, alterations or lack of maintenance. JET woodworking machinery is designed to be used with Wood. Use of these machines in the processing of metal, plastics, or other materials may void the warranty. The exceptions are acrylics and other natural items that are made specifically for wood turning.

Warranty Limitations

Woodworking products with a Five Year Warranty that are used for commercial or industrial purposes default to a Two Year Warranty. Please contact Technical Service at 1-800-274-6846 for further clarification.

How to Get Technical Support

Please contact Technical Service by calling 1-800-274-6846. **Please note that you will be asked to provide proof of initial purchase when calling.** If a product requires further inspection, the Technical Service representative will explain and assist with any additional action needed. JET has Authorized Service Centers located throughout the United States. For the name of an Authorized Service Center in your area call 1-800-274-6846 or use the Service Center Locator on the JET website.

More Information

JET is constantly adding new products. For complete, up-to-date product information, check with your local distributor or visit the JET website.

How State Law Applies

This warranty gives you specific legal rights, subject to applicable state law.

Limitations on This Warranty

JET LIMITS ALL IMPLIED WARRANTIES TO THE PERIOD OF THE LIMITED WARRANTY FOR EACH PRODUCT. EXCEPT AS STATED HEREIN, ANY IMPLIED WARRANTIES OF MERCHANTABILITY AND FITNESS FOR A PARTICULAR PURPOSE ARE EXCLUDED. SOME STATES DO NOT ALLOW LIMITATIONS ON HOW LONG AN IMPLIED WARRANTY LASTS, SO THE ABOVE LIMITATION MAY NOT APPLY TO YOU.

JET SHALL IN NO EVENT BE LIABLE FOR DEATH, INJURIES TO PERSONS OR PROPERTY, OR FOR INCIDENTAL, CONTINGENT, SPECIAL, OR CONSEQUENTIAL DAMAGES ARISING FROM THE USE OF OUR PRODUCTS. SOME STATES DO NOT ALLOW THE EXCLUSION OR LIMITATION OF INCIDENTAL OR CONSEQUENTIAL DAMAGES, SO THE ABOVE LIMITATION OR EXCLUSION MAY NOT APPLY TO YOU.

JET sells through distributors only. The specifications listed in JET printed materials and on official JET website are given as general information and are not binding. JET reserves the right to effect at any time, without prior notice, those alterations to parts, fittings, and accessory equipment which they may deem necessary for any reason whatsoever. JET® branded products are not sold in Canada by JPW Industries, Inc.

Product Listing with Warranty Period

90 Days – Parts; Consumable items
1 Year – Motors; Machine Accessories
2 Year – Metalworking Machinery; Electric Hoists, Electric Hoist Accessories; Woodworking Machinery used for industrial or commercial purposes
5 Year – Woodworking Machinery
Limited Lifetime – JET Parallel clamps; VOLT Series Electric Hoists; Manual Hoists; Manual Hoist Accessories; Shop Tools; Warehouse & Dock products; Hand Tools; Air Tools

NOTE: JET is a division of JPW Industries, Inc. References in this document to JET also apply to JPW Industries, Inc., or any of its successors in interest to the JET brand.

2.0 Table of contents

Section	Page
1.0 Warranty and Service.....	2
2.0 Table of contents.....	3
3.0 Safety warnings.....	4
4.0 About this machine and manual.....	5
5.0 Specifications.....	6
6.0 Setup and assembly.....	7
6.1 Shipping contents.....	7
6.2 Unpacking and cleanup.....	7
6.3 Tools required for assembly.....	7
6.4 Mounting the grinder.....	8
6.5 Exhaust ports.....	8
6.6 Assembling eye shield brackets to spark guards.....	8
6.7 Installing spark guards/brackets.....	8
6.8 Eye shields.....	8
6.9 Tool rests.....	8
6.10 Grinding wheel selection.....	9
6.11 Ring test.....	9
6.12 Grinding wheel installation.....	9
6.13 Wheel balancing.....	10
7.0 Electrical connections.....	10
7.1 Grounding instructions.....	11
7.2 Extension cords.....	11
8.0 Adjustments.....	11
8.1 Eye shield tilt adjustment.....	11
8.2 Spark guards.....	11
8.3 Tool rest adjustment.....	12
9.0 Operation.....	12
9.1 Switch.....	12
9.2 Precautions.....	12
10.0 Maintenance.....	12
10.1 Care of grinding wheels.....	12
10.2 Changing wheels.....	12
10.3 Cleaning.....	13
10.4 Lubrication.....	13
11.0 Optional accessory.....	13
12.0 Troubleshooting the JWBG-8.....	14
13.0 Replacement Parts.....	15
13.1.1 JWBG-8 Bench Grinder – Exploded View.....	16
13.1.2 JWBG-8 Bench Grinder – Parts List.....	17
14.0 Electrical Connections.....	19



3.0 Safety warnings

1. Read and understand the entire owner's manual before attempting assembly or operation.
2. Read and understand the warnings posted on the machine and in this manual. Failure to comply with all of these warnings may cause serious injury.
3. Replace warning labels if they become obscured or removed.
4. Do not use this grinder for other than its intended use. If used for other purposes, JET disclaims any real or implied warranty and holds itself harmless from any injury that may result from that use.
5. Always use the grinder's eye shields. In addition, wear ANSI Z87.1 approved safety glasses, or a face shield. (*Everyday eyeglasses only have impact resistant lenses; they are NOT safety glasses.*)
6. Before operating grinder, remove tie, rings, watches and other jewelry, and roll sleeves up past elbows. Do not wear loose-fitting clothing. Confine long hair.
7. Wear protective clothing such as apron or safety shoes, where the grinding activity presents a hazard to the operator.
8. Wear ear protectors (plugs or muffs) if the particular work requires it.
9. Some dust created by power sanding, sawing, grinding, drilling and other construction activities contain chemicals known to cause cancer, birth defects or other reproductive harm. Some examples of these chemicals are:
 - Lead from lead based paint.
 - Crystalline silica from bricks, cement and other masonry products.
 - Arsenic and chromium from chemically treated lumber.Your risk of exposure varies, depending on how often you do this type of work. To reduce your exposure to these chemicals, work in a well-ventilated area and work with approved safety equipment, such as face or dust masks that are specifically designed to filter out microscopic particles.
10. Do not operate this machine while tired or under the influence of drugs, alcohol or any medication.
11. Make certain the switch is in the OFF position before connecting the machine to the power supply.
12. Make certain the machine is properly grounded.
13. Make all machine adjustments or maintenance with the machine unplugged from the power source.
14. Remove adjusting keys and wrenches. Form a habit of checking to see that keys and adjusting wrenches are removed from the grinder before turning it on.
15. Keep safety guards in place at all times when the machine is in use. If removed for maintenance purposes, use extreme caution and replace the guards immediately after completion of maintenance.
16. Check damaged parts. Before further use of the machine, a guard or other part that is damaged should be carefully checked to determine that it will operate properly and perform its intended function. Check for alignment of moving parts, binding of moving parts, breakage of parts, mounting and any other conditions that may affect its operation. A guard or other part that is damaged should be properly repaired or replaced.
17. Provide for adequate space surrounding work area and non-glare, overhead lighting.
18. Keep the floor around the machine clean and free of scrap material, oil and grease.
19. Keep visitors a safe distance from the work area. **Keep children away.**
20. Make your workshop child proof with padlocks, master switches or by removing starter keys.
21. Give your work undivided attention. Looking around, carrying on a conversation and "horse-play" are careless acts that can result in serious injury.
22. Maintain a balanced stance at all times so that you do not fall into the tool or other moving parts. Do not overreach or use excessive force to perform any machine operation.
23. Disconnect grinder before servicing and when changing abrasive wheels.
24. Use recommended accessories. The use of improper accessories may cause risk of injury to persons.
25. Turn off the machine before cleaning. Use a brush or compressed air to remove chips or debris — do not use your hands.
26. Never leave the grinder running unattended. Turn power off and do not leave machine until wheels come to a complete stop.

27. Remove loose items and unnecessary work pieces from the area before starting the grinder.
28. Don't use in dangerous environment. Don't use power tools in damp or wet location, or expose them to rain. Keep work area well lighted.
29. Inspect abrasive wheels for cracks or other forms of damage. Perform a "ring test" to check wheel integrity (see *section 6.10*). Do not use a faulty or damaged wheel.
30. Verify that maximum RPM of abrasive wheels is compatible with speed of grinder.
31. Allow abrasive wheels to reach full RPM before starting the grinding operation.
32. Do not crowd the work so that the wheels slow.
33. Tool rest should be adjusted less than 1/8" from wheel surface.
34. Do not grind on side of wheel; do all work on the grinding face or edge near the tool rest.
35. Do not grind aluminum or magnesium, as these may pose a fire hazard.

Familiarize yourself with the following safety notices used in this manual:

CAUTION This means that if precautions are not heeded, it may result in minor injury and/or possible machine damage.

WARNING This means that if precautions are not heeded, it may result in serious injury or possibly even death.

4.0 About this machine and manual

The JET JWBG-8 Bench Grinder is designed primarily for woodworkers, suitable for grinding and sharpening lathe turning chisels, gouges, knives, plane irons, carving tools, and more. Abrasive wheels are protected by cast iron guards. The tool rests are adjustable, with a tilt angle scale and incised lines to help align tools square to the wheel. A steel spark guard and plexiglass eye shield provide safety (personal eye protection still required). Rubber foot pads prevent sliding. Alternatively, mounting holes are provided in the base for securing the unit to a bench or stand.

This manual is provided by JET covering the safe operation and maintenance procedures for a JET Model JWBG-8 Bench Grinder. This manual contains instructions on assembly, safety precautions, general operating procedures, maintenance instructions and parts breakdown. Your bench grinder has been designed and constructed to provide years of trouble-free operation if used in accordance with the instructions as set forth in this document.

The operator is encouraged to familiarize himself/herself with ANSI B7.1 – *Safety Requirements for Use, Care and Protection of Abrasive Wheels*.

If there are questions or comments, please contact your local supplier or JET. JET can also be reached at our website: www.jettools.com.

Retain this manual for future reference. If the grinder transfers ownership, the manual should accompany it.

WARNING Read and understand the entire contents of this manual before attempting assembly or operation! Failure to comply may cause serious injury!

5.0 Specifications

Model number JWBG-8

Stock numbers:

Bench Grinder with two Norton grinding wheels 726100
Bench Grinder only (no grinding wheels) 726101

Motor and electricals:

Motor type induction, capacitor start, with centrifugal switch
Horsepower 1/2 HP
Phase single
Voltage 115V
Cycle 60Hz
Listed FLA (full load amps) 6.5 A
On/off switch toggle
Motor speed 1725 RPM
Power cable size 16AWG
Power cable length 6 ft. (182cm)
Power plug installed yes
Recommended circuit size¹ 15 A

¹ subject to local/national electrical codes.

Arbor and grinding wheels:

Arbor diameter 5/8" (16 mm)
Wheel size (dia. x width) 8" x 1" (16 x 25.4mm)
Wheel bore 5/8" (16mm)
Wheel grits (provided with 726100) 80G ceramic aluminum; and 100G aluminum oxide
Wheel flange diameter 2.86"
Arbor nut maximum tightening torque 10.12 lbf-ft (140 kgf-cm)
Distance bench top to arbor centerline 6.18" (157mm)

Toolrests:

Tilt angle 45° forward
Distance to wheel adjustable

Materials:

Arbor steel
Base cast iron
Body cast iron and aluminum
Wheel guards cast iron and aluminum
Wheel flanges steel
Tool rests cast iron with milled surface
Eye shields clear acrylic
Spark guards steel
Knobs polyimide

Dimensions:

Mounting hole centers 7.244" (184mm)
Mounting hole diameters 3/8" (9.5mm)
Footprint (width x depth) 8-1/4" x 6-1/4" (210 x 158mm)
Overall dimensions, assembled (width x depth x height) 20-1/4" x 12" x 12-1/2" (514 x 305 x 318mm)
Shipping carton dimensions (width x depth x height) 22-1/4" x 14-3/8" x 14" (565 x 365 x 358mm)

Dust/swarf collection:

Dust port outside diameter 2" (50mm)
Recommended minimum extraction volume 350 CFM

Weights:

Net 57.2 lb (26kg)
Shipping 62.7 lb (28.5kg)

The specifications in this manual were current at time of publication, but because of our policy of continuous improvement, JET reserves the right to change specifications at any time and without prior notice, without incurring obligations.

6.0 Setup and assembly

6.1 Shipping contents

Carton contents (see Figure 1)

Qty.	Item
1	Bench grinder (not shown)
1	Spark guard – Left (A)
2	Lock knob (B)
1	Spark guard – Right (C)
1	Eye shield bracket – Left (D)
2	Cross head screw 1/4" x 1/2" (E)
1	Eye shield bracket – Right (F)
2	Eye shield plate (G)
4	Socket head cap screw 5/16" x 3/4" (H)
6	Flat washer 5/16" (J)
4	Pan head screw 3/16" x 3/8" (K)
4	Hex head screw 1/4" x 3/8" (L)
6	Flat washer 1/4" (M)
2	Lock washer 1/4" (N)
1	Tool rest – Left (O)
1	Tool rest – Right (P)
1	Tool rest bracket – Left (Q)
1	Tool rest bracket – Right (R)
2	Lock knob (S)
2	Eye shield (T)
4	Flange (U)
2	Grinding wheels (not shown; provided only with stock no. 726100)

6.2 Unpacking and cleanup

Remove all contents from shipping carton. Check for shipping damage; if any is found report it to your distributor.

Do not discard carton or packing material until grinder is assembled and running satisfactorily.

Compare contents of shipping carton with the contents list above. Report any shortages to your distributor. (Check grinder first to verify if any parts have been pre-assembled.)

6.3 Tools required for assembly

- 1/4" hex key
- 10mm wrench
- 1" wrench (or adjustable wrench)
- Cross-point screwdriver #1 or #2

Your bench grinder requires only the assembly of the eye shields, tool rests, and grinding wheels. Additional tools may be needed for fastening the grinder to a workbench or stand. For your safety, do not plug the grinder into a power source until all assembly and adjustments are complete.

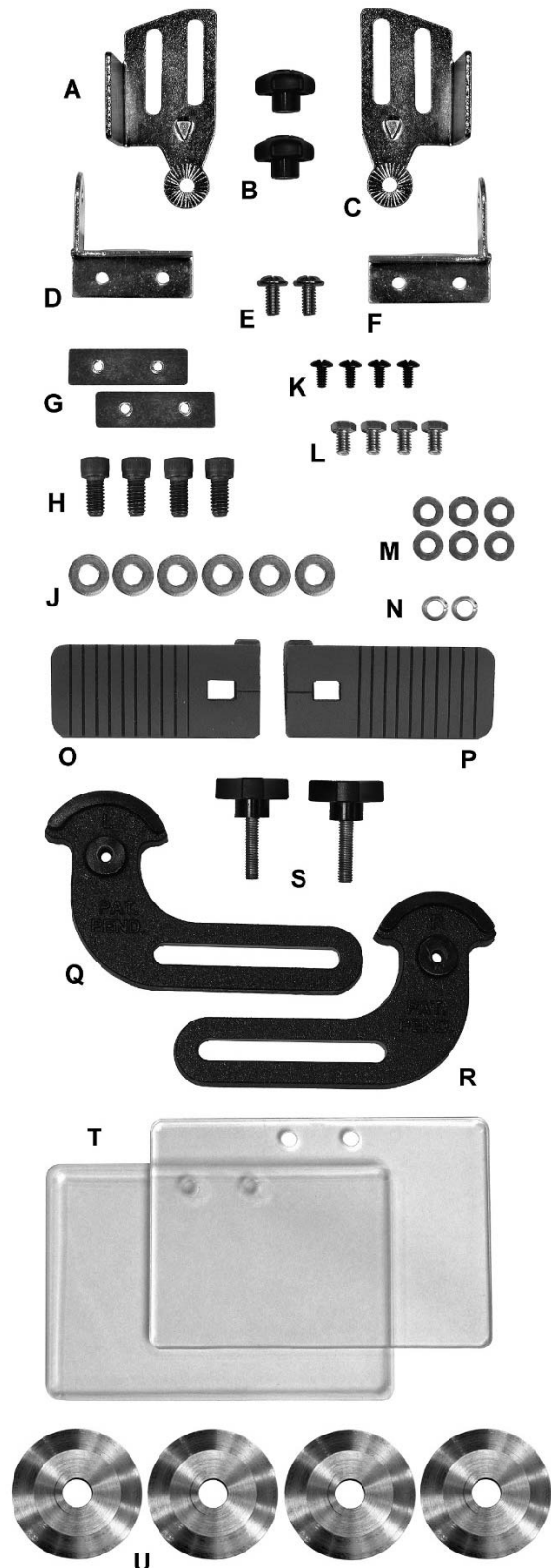

Figure 1: shipping contents (not to scale)

6.4 Mounting the grinder

The grinder is provided with rubber pads to help prevent movement on a bench. For best results, however, it is recommended the grinder be bolted to the work surface or a grinder stand (fasteners not included).

1. Align mounting holes on grinder with predrilled holes in a bench or grinder stand. Refer to Figure 2 for hole spacing.
2. Insert bolts through the holes, and tighten using washers and nuts.

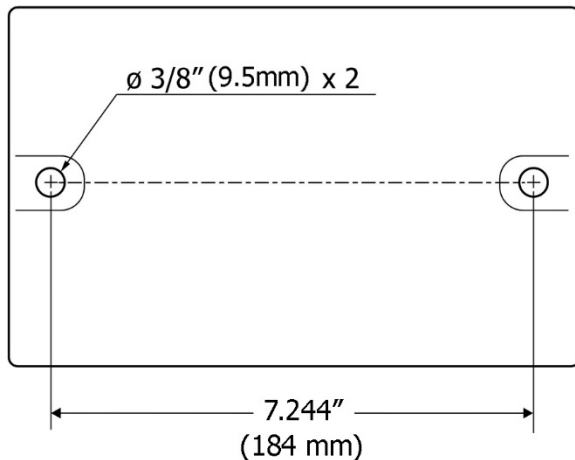

Figure 2: mounting holes

6.5 Exhaust ports

A collection system designed for metal dust and swarf can be connected to the two exhaust ports at rear of grinder.

CAUTION Do not connect a dust collector designed for wood dust and shavings to the bench grinder, as this can pose a fire hazard. Use only a dust capture system designed for metal dust and swarf.

6.6 Assembling eye shield brackets to spark guards

Refer to Figure 3.

Note: Spark guards (A) and Brackets (D) are marked **L** for left side assembly and **R** for right side assembly.

1. Assemble the left spark guard (A) and eye shield bracket (D) using Figure 3 as a guide. Make sure spark guard and bracket are marked **L**.
2. Install the right assembly in the same manner.

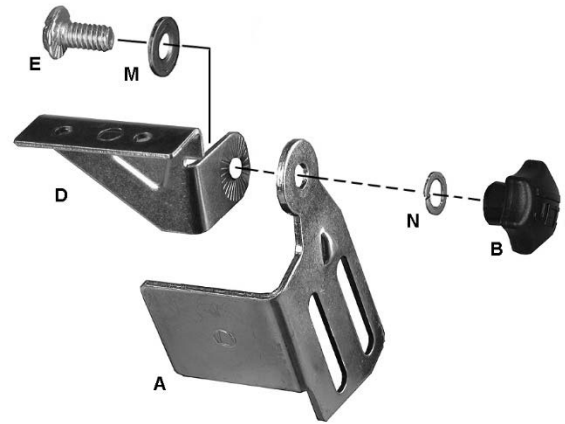

Figure 3: brackets to spark guards

6.7 Installing spark guards/brackets

Refer to Figure 4.

1. Install the left spark guard and bracket to the left wheel housing with two 1/4 x 3/8 hex cap screws (L) and two 1/4 flat washers (M).
2. The spark guard should be adjusted to within 1/16" of the grinding wheel surface or other accessory being used.
3. Install the right spark guard and bracket in the same manner.

Note: As the wheel wears down, the spark guards should be readjusted to maintain the 1/16" distance from wheel.

6.8 Eye shields

Refer to Figure 4.

The eye shields (T) are identical and will fit on either side of the grinder.

1. Insert two 3/16 x 3/8 pan head screws (K) through the eye shield bracket, eye shield (T), and eye shield plate (G) which contains threaded holes.
2. Tighten the screws (K).

6.9 Tool rests

Refer to Figure 4.

Note: There is a *left* and a *right* tool rest. Refer to Figure 4 to ensure that you install them correctly. (The beveled edge of tool rest faces the wheel.)

1. Install the left tool rest bracket (Q) by threading two 5/16 x 3/4 hex cap screws (H) through two 5/16 flat washers (J) and the tool rest bracket (Q) into the wheel housing.
2. Place the tool rest (O) over the bracket (Q) so that the scale is seen through the cutout. Secure with knob (S).
3. Install the right tool rest in the same manner.

The tool rests must not contact the grinding wheel, but should ideally be adjusted to within 1/16" of the wheel, depending upon the type of tool being ground. As a wheel wears down, the tool rest should be readjusted to maintain this clearance.

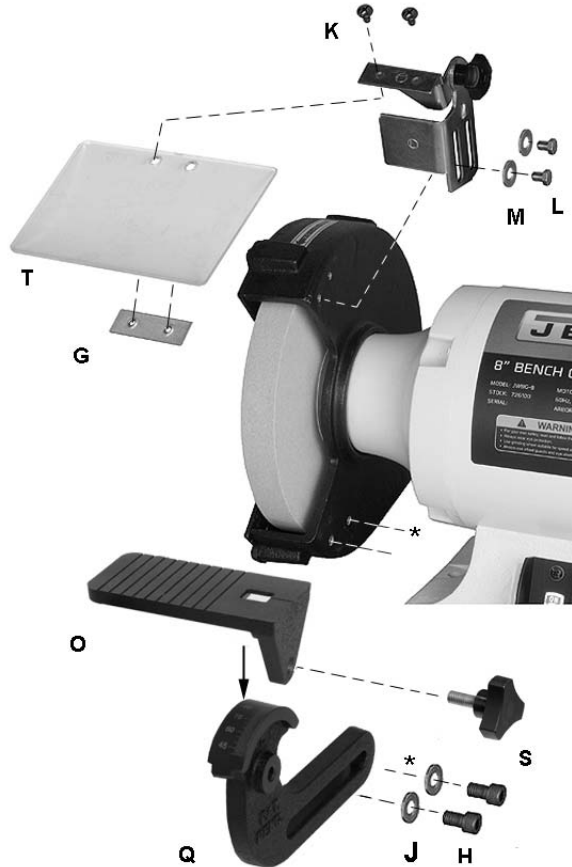

Figure 4: completion of assembly

6.10 Grinding wheel selection

Abrasive wheels are generally designed around five characteristics: material, wheel grade, grain size, grain spacing, and type of bond. These codes will usually be listed on a wheel's label.

General-use silicon-carbide (carborundum) wheels can overheat and ruin the temper of high quality tool steel. For sharpening woodworking tools, an *aluminum oxide* wheel is recommended.

Always inspect an abrasive wheel before mounting. (See *section 6.10, Ring test.*) A wheel that is cracked or damaged in any way must **not** be used. Maximum operating speed – listed on the abrasive wheel label – must meet or exceed 1725 RPM (grinder spindle speed).

6.11 Ring test

An internal defect, such as a crack or void, may not be apparent by visual inspection alone. Before installing a grinding wheel, check its internal integrity by performing a simple "ring test".

1. Suspend wheel from the hole by a small pin or finger.
2. Gently tap the flat side of the wheel with a non-metallic object, such as a wood dowel or the handle of a screwdriver. Tap about 45° to each side of vertical center line, and about 1" to 2" from the periphery. Then rotate wheel 45° and repeat.
3. A good wheel will "ring"; a defective wheel will "thud", indicating cracks or other internal compromise. Discard any wheel that does not "ring".

WARNING A cracked or otherwise damaged grinding wheel can break apart and, if unguarded, exit grinder at high velocity causing injury. Regularly inspect wheels for damage, and make sure all guards are in position.

6.12 Grinding wheel installation

Refer to Figure 5:

1. Unplug grinder from power source.
2. Move tool rest and eye shield out of the way.
3. Remove wheel guard.
4. Remove arbor nut (1" wrench) and outer flange. (**NOTE: The left arbor nut has left-hand threads; rotate clockwise to loosen.**)
5. Make sure that inner flange is seated properly against shoulder of arbor.
6. Install wheel, outer flange and nut. Make snug the nut using the 1" wrench – do not overtighten, as this may cause deflection of the flanges.
7. Repeat for opposite side.
8. Inspect wheel for proper balance, as described in *section 6.13*. An out-of-balance wheel will result in excessive vibration and poor surface finish of tools.

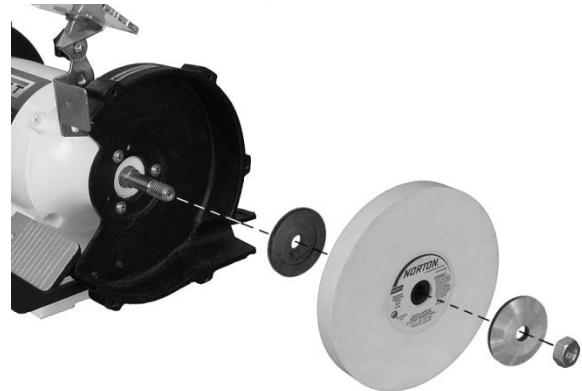

Figure 5: wheel mounting

6.13 Wheel balancing

With the grinder **unplugged from the power source**, and arbor nuts snugged down, rotate wheels by hand and observe their motion.

A grinding wheel has proper balance when:

1. The wheel's outside face spins true and round; that is, its circumference rotates concentric to the arbor.
2. There is no side-to-side wobble.

The operator who takes time to patiently perform needed adjustments will be rewarded by wheels running true, and accurate grinding of work pieces.

6.13.1 Adjusting concentricity

If the outside face is not rotating concentric to arbor, try shifting the wheel closer to arbor centerline before tightening the nut. See A, Figure 6.

Another method of achieving concentricity is the use of a wheel dresser (not provided). "Dressing" is the removal of the current layer of abrasive to expose a fresh surface. A wheel dresser is also used to "true" a wheel; that is, to make the grinding surface parallel to the tool rest, so the entire wheel presents an even surface to the work piece. Proper use of a wheel dresser will eliminate high spots and result in concentric rotation about the arbor, as well as minimize vibration. (Always follow the wheel dresser manufacturer's instructions.)

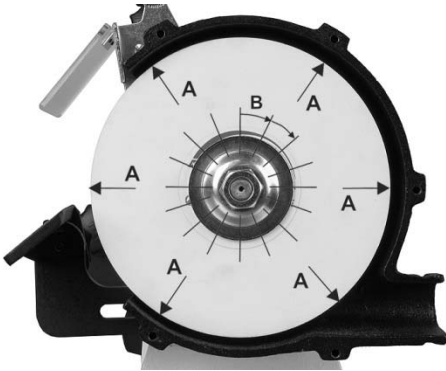

Figure 6: wheel balancing

6.13.2 Correcting side-to-side wobble

1. Loosen nut and rotate the outer flange a little. Snug the nut and spin the wheel by hand to check.
2. If wobble still exists, continue repeating step 1, rotating outer flange incrementally in the same direction. See B, Figure 6. Make sure to keep the wheel in the same position each time.
3. If complete rotation of outer flange has proved ineffective, remove nut, outer flange, and wheel (keep wheel in same orientation by placing a pencil mark on it somewhere for reference). Then rotate inner flange about 90°

and repeat the above steps for the outer flange.

4. Continue this combination of flange movements until the wobble is eliminated.

If required, a shim made of thick paper or card stock may be placed between flange and wheel side.

NOTE: Very slight wobble may still exist at spin-up and spin-down, but will not affect normal speed operation.

If excessive wobble still exists after performing the above remedies, consult *section 12.0* for further possibilities. When troubleshooting, keep in mind these possible sources of imbalance:

1. Wheel not concentric.
2. Wheel wobbles side-to-side.
3. Wheel arbor bushing has play in it.
4. Wheel is poor quality.
5. Flanges are warped.

7.0 Electrical connections

The JWBG-8 Bench Grinder is rated at 115 volt power. The grinder is supplied with a plug designed for use on a circuit with a 110-120V *grounded outlet* that looks like the one pictured in A, Figure 7.

Before connecting to power source, be sure switch is in *off* position.

It is recommended the grinder be connected to a 15 amp circuit with a 15 amp circuit breaker or time-delay fuse marked "D". **Local codes take precedence over recommendations.**

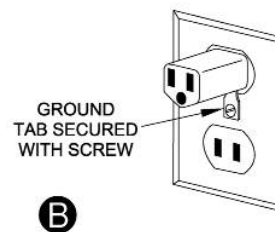
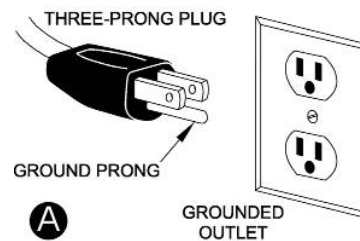

Figure 7: plug and receptacle

7.1 Grounding instructions

1. All Grounded, Cord-connected Tools:

In the event of a malfunction or breakdown, grounding provides a path of least resistance for electric current to reduce the risk of electric shock. This tool is equipped with an electric cord having an equipment-grounding conductor and a grounding plug. The plug must be plugged into a matching outlet that is properly installed and grounded in accordance with all local codes and ordinances.

Do not modify the plug provided – if it will not fit the outlet, have the proper outlet installed by a qualified electrician.

Improper connection of the equipment-grounding conductor can result in a risk of electric shock. The conductor with insulation having an outer surface that is green with or without yellow stripes is the equipment-grounding conductor. If repair or replacement of the electric cord or plug is necessary, do not connect the equipment-grounding conductor to a live terminal.

⚠ WARNING Check with a qualified electrician or service personnel if the grounding instructions are not completely understood, or if in doubt as to whether the tool is properly grounded. Failure to comply may cause serious or fatal injury.

Use only 3-wire extension cords that have 3-prong grounding plugs and 3-pole receptacles that accept the tool's plug.

Repair or replace damaged or worn cord immediately.

2. Grounded, cord-connected tools intended for use on a supply circuit having a nominal rating **less than 150 volts**:

This tool is intended for use on a circuit that has an outlet that looks like the one illustrated in **A**, Figure 2. An adapter, shown in **B**, Figure 2, may be used to connect this plug to a 2-pole receptacle if a properly grounded outlet is not available. The temporary adapter should be used only until a properly grounded outlet can be installed by a qualified electrician. *This adapter is not permitted in Canada.* The green-colored rigid ear, lug, and the like, extending from the adapter must be connected to a permanent ground such as a properly grounded outlet box.

7.2 Extension cords

USE PROPER EXTENSION CORD. Use only three-wire extension cords that have three-prong grounding type plugs and three-prong receptacles that accept the tool's plug.

Make sure your extension cord is in good condition. When using an extension cord, be sure to use one heavy enough to carry the current your

product will draw. An undersized cord will cause a drop in line voltage resulting in loss of power and overheating. Table 1 shows correct size to use depending on cord length and nameplate ampere rating. If in doubt, use the next heavier gauge. The smaller the gauge number, the heavier the cord.

Amp Rating	Volts	Total length of cord in feet			
	120 240	25 50	50 100	100 200	150 300
AWG					
0 - 6		18	16	16	14
6 - 10		18	16	14	12
10 - 12		16	16	14	12
12 - 16		14	12	Not Recommended	

Table 1: extension cord recommendations

8.0 Adjustments

⚠ WARNING Disconnect saw from power source before making adjustments.

8.1 Eye shield tilt adjustment

1. Loosen lock knob (B, Figure 8).
2. Adjust eye shield (T) to desired tilt angle.
3. Tighten lock knob (B).

8.2 Spark guards

As the wheel wears down, the spark guards must be readjusted to maintain 1/16" distance from the wheel.

To adjust:

1. Loosen two hex cap screws (L, Figure 8) with a 10mm wrench.
2. Slide the spark guard to 1/16" distance from grinding wheel surface.
3. Tighten screws (L).

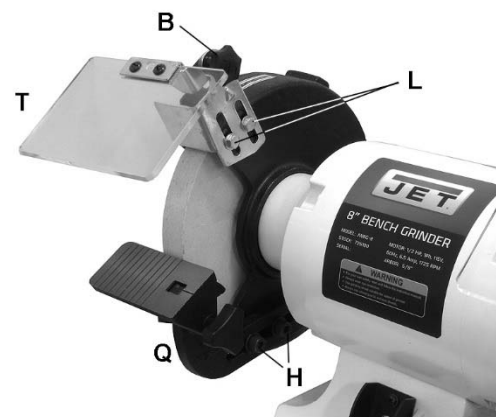

Figure 8: eye shield and tool rest adjustment

8.3 Tool rest adjustment

As the wheel wears down, the tool rest must be re-adjusted to maintain a 1/16" to 1/8" distance.

1. Loosen two hex cap screws (H, Figure 8) with a 12mm wrench.
2. Slide tool rest bracket (Q) as needed.
3. Tighten screws (H).

9.0 Operation

A bench grinder is designed for hand-grinding operations such as sharpening chisels, screwdrivers, drill bits, removing excess metal, and smoothing metal surfaces.

A *Medium Grain Abrasive Grinding Wheel* is suitable for rough grinding where a considerable amount of metal must be removed or when obtaining a smooth finish is not important.

A *Fine Grain Abrasive Grinding Wheel* should be used for sharpening tools to close size tolerances because it removes metal more gradually for precision grinding and gives work a smooth finish.

⚠WARNING Do not operate this grinder without all guards and shields in place and in working order. Always use approved safety glasses or face shields. Failure to comply may cause serious injury.

9.1 Switch

The toggle switch guard will accept a padlock, as shown in Figure 9. To safeguard the grinder from unauthorized operation and accidental starting by young children, use of a padlock (not provided) is highly recommended. Place the key in a location inaccessible to children and others not qualified to use the tool.

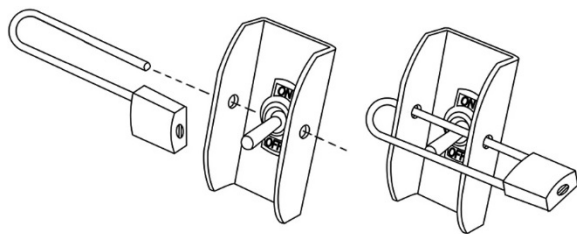

Figure 9 – switch lockout (padlock not provided)

9.2 Precautions

Before starting the grinder, turn the wheels by hand to verify they are clear of obstructions and will turn freely. Tool rests and spark guards should not touch the wheel.

Adjust spark arrestor, eye shield, and tool rest into proper positions. Stand to one side of the wheel

paths, and turn on the grinder. Allow it to reach full running speed before beginning operation.

Keep a steady, moderate pressure on the workpiece and keep it moving at an even pace for smooth grinding. Pressing too hard overheats the motor and prematurely wears down the grinding wheels. Note the original bevel angle on the item to be sharpened and try to maintain the same shape. The tilt scale on the tool rest will aid in establishing this angle. The grinding wheel should rotate into the object being sharpened. Keep a tray filled with water and dip your work into it regularly to prevent overheating. Overheating can weaken metals.

Do not use the side of the grinding wheel; this puts dangerous stress on the wheel.

When the wheel becomes loaded or dull, use an approved grinding wheel dresser and dress the wheel face.

Keep tool rest and spark guard to within 1/16" of the grinding wheel. See *Adjustment* section to adjust.

10.0 Maintenance

⚠WARNING Always disconnect power to the machine before performing maintenance. Failure to do this may result in personal injury.

For safety, turn the switch to OFF and remove plug from the power source outlet before adjusting or servicing the bench grinder. If the power cord is worn, cut or damaged in any way, have it replaced immediately.

10.1 Care of grinding wheels

In normal use, grinding wheels may become cracked, grooved, rounded at the edges, chipped, out of true or loaded with foreign material.

Cracked wheels should be replaced **immediately**. While any of the other conditions can be remedied with a dressing tool (available at most hardware stores), new wheels sometimes require dressing to make them round.

10.2 Changing wheels

If you must replace a wheel be sure to obtain one with a safe rated speed at least as high as the *NO LOAD RPM* marked on the grinder's nameplate. Table 2 shows correct dimensions for the replacement wheel.

	Wheel Diameter	Maximum width	Center hole
JWBG-8	8"	3/4"	5/8"

Table 2

Test new wheels for cracks and maintain the existing sequence of retaining hardware. Be sure the grinder is unplugged before attempting repairs.

To change a wheel (refer to Figure 5):

1. Disconnect grinder from power source.
2. Move spark guard and tool rest away from the wheel.
3. Remove the guard cover using a Phillips or flathead screwdriver.
4. Stabilize the wheel by holding the opposite wheel firmly.
5. Unscrew the arbor nut with a 1" wrench.

Note: Turn the locking nut on the right-hand wheel counterclockwise to loosen. Turn the locking nut on the left-hand wheel clockwise to loosen.

6. Remove the outer flange and wheel.
7. Clean flanges. Check the flanges to make sure they are flat. Wheel flanges that are not flat will cause the wheel to wobble.
8. Install the inner flange, wheel, outer flange, and nut on the arbor. Tighten the nut. **Do not over tighten** – this may cause the wheel to crack, or the flanges to bend.
9. Replace the guard cover. Adjust spark guards and tool rests to 1/16" clearance from wheel.

10.3 Cleaning

CAUTION Metal shavings may still be hot from recent grinding operations. Make sure shavings and debris are cold before cleaning the grinder.

Brush all shavings from the motor housing, tool rests, and wheel guards.

Check grinding wheels for cracks and chips. Replace if damaged.

CAUTION Avoid the use of the following cleaning chemicals or solvents: gasoline, carbon tetrachloride, chlorinated solvents, ammonia and household detergents containing ammonia.

10.4 Lubrication

All motor bearings are permanently lubricated by the manufacturer and require no additional lubrication.

11.0 Optional accessory

The bench grinder can be mounted to the JET pedestal stand (optional accessory, p/n 577172), which has an adjustable platform with coolant cup. See Figure 10. To order, contact your dealer or call JET customer service at the phone number on the cover.



Figure 10: optional stand

12.0 Troubleshooting the JWBG-8

Table 3

Problem	Probable Cause	Remedy
Motor will not start.	Not plugged into receptacle.	Plug must be fully inserted into receptacle.
	Switch not in ON position.	Make sure switch is moved completely to ON position.
	Motor cord cut or abraded.	Replace with new cord.
	Plug on cord is faulty.	Replace with new plug.
	Fuse blown or circuit breaker tripped.	Re-set. (There may be too many machines on circuit.)
	Motor faulty.	Contact JET Customer Service.
Motor will not start and fuse blows or circuit breaker trips.	Too many machines running on same electrical circuit.	Turn off other machines and try again.
	Incorrect fuse.	Try time delay fuse, or go to circuit with higher rated fuse or circuit breaker.
	Wheels cannot rotate because of obstruction.	Unplug and turn grinding wheel by hand; clear any obstructions.
	Undersized extension cord.	Use correct size extension cord; see Table 1.
	Short circuit.	Cord, plug, or motor needs repair; contact JET Customer Service.
Motor fails to develop full power.	Low line voltage.	Have an electrician check power line for proper voltage.
	Faulty motor or capacitor.	Contact JET Customer Service.
Motor overheats.	Overload on motor.	Reduce load on motor; do not press so hard.
	Capacitor failure.	Call JET Customer Service.
Motor stalls or slows.	Motor overload.	Reduce load on motor; do not press so hard.
	Low line voltage.	Check power line for proper voltage.
	Loose wire connections.	Contact JET Customer Service.
	Faulty motor.	Contact JET Customer Service.
Frequent fuse or circuit breaker failure.	Motor overload.	Reduce load on motor; do not press so hard.
	Overload of electrical circuit.	Too many electrical appliances on same circuit.
	Incorrect fuse or circuit breaker.	Have electrician upgrade service to outlet.
Grinding wheels won't spin true.	Arbor nut too tight, springing the flanges.	Do not overtighten nut.
	Flange(s) warped, or flange surface is not flat.	Replace flange(s).
	Wheel bushings have too much play.	Install new bushings or replace wheel.
	Arbor damaged.	Contact JET Customer Service.
Excessive vibration.	Incorrect size or type of wheel.	Match wheel size to grinder specifications. Use proper wheel type for job being done.
	Wheels out of balance.	Balance wheels. See section 6.13
	Too much play in wheel bushing.	Install new bushings or replace wheel.
	Flanges are worn, bent or have burrs.	Inspect flanges, replace if needed.
	Worn bearings in grinder.	Replace bearings. Contact JET Customer Service.
	Poor quality wheel.	Replace wheel with one of better quality.

13.0 Replacement Parts

Replacement parts are listed on the following pages. To order parts or reach our service department, call 1-800-274-6848 Monday through Friday (see our website for business hours, www.jettools.com). Having the Model Number and Serial Number of your machine available when you call will allow us to serve you quickly and accurately.

13.1.1 JWBG-8 Bench Grinder – Exploded View

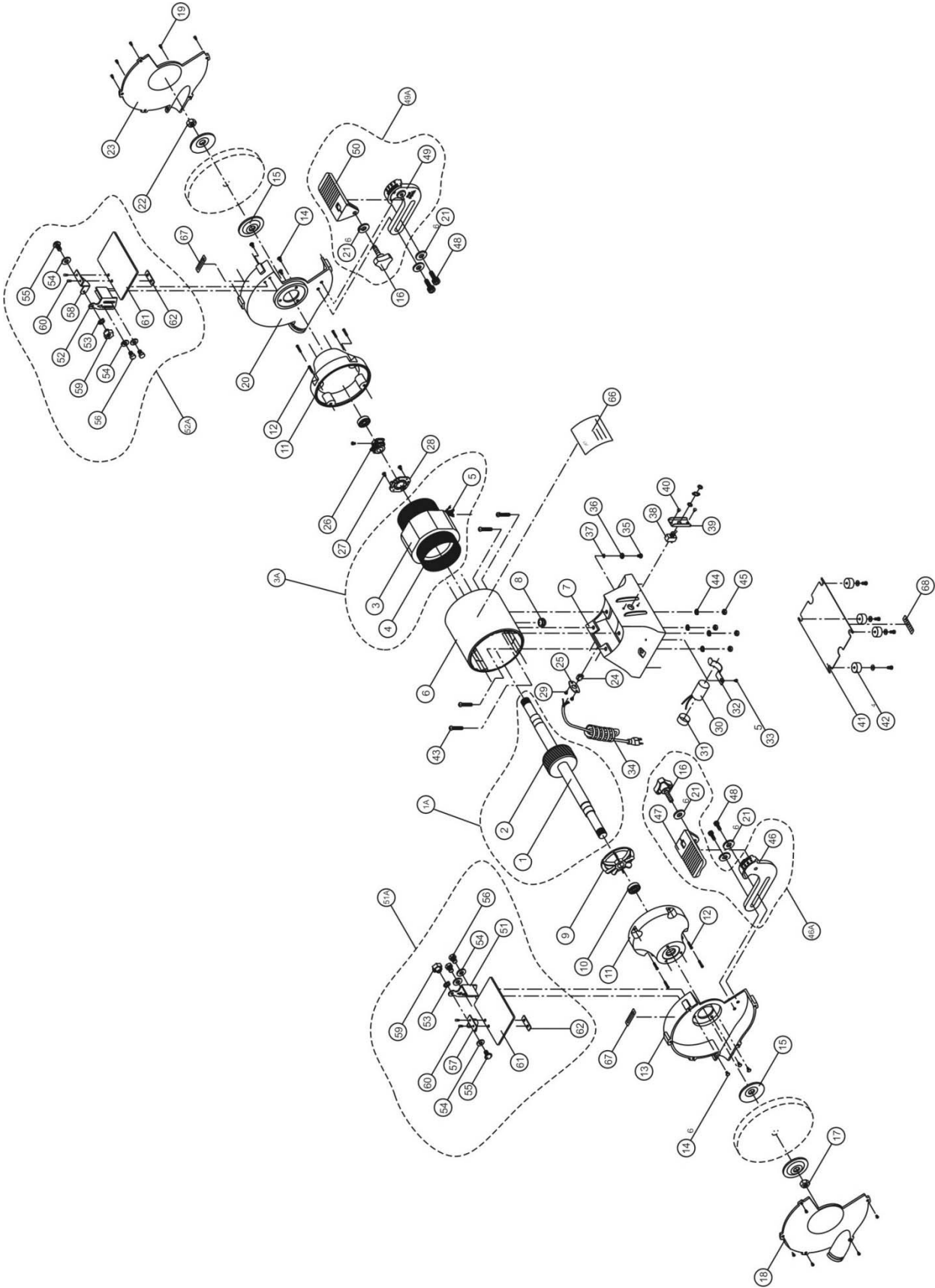

13.1.2 JWBG-8 Bench Grinder – Parts List

Index No	Part No	Description	Size	Qty
1A	JWBG8-01A	Rotor Assembly		1
1	JWBG8-01	Arbor (RE: JWBG8-01A)		1
2	JWBG8-02	Rotor (RE: JWBG8-01A)		1
3A	JWBG8-03A	Stator Assembly		1
3	JWBG8-03	Stator (RE: JWBG8-03A)		1
4	JWBG8-04	Coil (RE: JWBG8-03A)		1
5	JWBG8-05	Export Wire (RE: JWBG8-03A)		1
6	JBG8A-05W	Motor Housing		1
7	JBG8A-06W	Base		1
8	JWBG8-08	Bushing	16 x 1mm	1
9	JBG8A-10	Fan		1
10	BB-6204ZZ	Ball Bearing	6204ZZ	2
11	JBG8A-12W	Cover		2
12	JBG6A-15	Screw	3/16 x 5/8	8
13	JBG8A-16B	Inner Wheel Guard – left (serial # 15100001 and higher)		1
14	JBG8A-19	Cross Head Screw	1/4 x 1/2	6
15	JWBG8-15	Wheel Flange	5/8 I.D	4
16	JWBG8-16	Triangle Knob	5/16 x 1-1/4	2
17	JBG8A-22	Nut - left hand thread	5/8	1
18	JBG8A-24P	Outer Wheel Guard – left		1
19	JBG8A-19	Cross Head Screw	1/4 x 1/2	10
20	JBG8A-17B	Inner Wheel Guard – right (serial # 15100001 and higher)		1
21	TS-0680031	Flat Washer	5/16	6
22	JBG8A-23	Nut – right hand thread	5/8	1
23	JBG8A-25P	Outer Wheel Guard – right		1
24	JBG8A-31	Rubber Guide		1
25	JBG8A-32	Cord Plate		1
26	JWBG8-26	Centrifugal Start Switch		1
27	JWBG8-27	Cross Head Screw	3/16 x 3/8	2
28	JWBG8-28	Switch Seat		1
29	JBG6A-34	Cross Screw	3/16 x 1/4	2
30	JBG8A-35	Capacitor	125 VAC, 200MFD	1
31	JWBG8-31	Capacitor Cover		1
32	JBG8A-36	Bracket		1
33	JBG6A-34	Screw	3/16 x 1/4	1
34	JBG8A-39	Power Cord		1
35	JBG6A-34	Cross Head Screw	3/16 x 1/4	1
36	JWBG8-36	Copper Washer	M5	1
37	JMS10SCMS-36	External Tooth Lock Washer	M5	1
38	JBG8A-44	Switch		1
39	JBG8A-45	Switch Plate		1
40	JBG6A-34	Screw	3/16 x 1/4	2
41	JBG8A-47	Base Plate		1
42	JWBG8-42	Rubber Foot w/Screw		4
43	JWBG8-43	Screw	1/4 x 7/8	4
44	TS-0720071	Lock Washer	1/4	4
45	TS-0570011	Hex Nut	1/4	4
46A	JWBG8-46A	Tool Rest Assembly – left		1
46	JWBG8-46	Tool Rest Bracket – left		1
47	JWBG8-47	Tool Rest – left		1
48	TS-0208041	Socket Head Cap Screw	5/16 x 3/4	4
49A	JWBG8-49A	Tool Rest Assembly – right		1
49	JWBG8-49	Tool Rest Bracket – right		1
50	JWBG8-50	Tool Rest – right		1
51A	JWBG8-51A	Eye Shield Assembly – left		1
51	JBG8A-50	Eye Shield Fixture (Spark Guard) – left		1
52A	JWBG8-52A	Eye Shield Assembly - right		1
52	JBG8A-51	Eye Shield Fixture (Spark Guard) – right		1
53	TS-0720071	Lock Washer	1/4	2
54	TS-0680021	Flat Washer	1/4	6

Index No	Part No	Description	Size	Qty
55	JBG8A-54	Cross Head Screw	1/4 x 1/2	2
56	6295480	Hex Head Screw	1/4 x 3/8	4
57	JBG8A-55	Eye Shield Bracket – left		1
58	JBG8A-56	Eye Shield Bracket – right		1
59	JBG6A-57	Lock Knob	1/4	2
60	JBG6A-58	Cross Head Screw	3/16 x 3/8	4
61	JBG8A-59	Eye Shield		2
62	JBG6A-60	Eye Shield Fixed Plate		2
66	JWBG8-66	I.D. Label		1
67	JBG6A-63	Direction Label		1
68		Serial Number Label		1
		Grinding Wheels (local purchase)*		2

Note: Some parts may be shown for reference only, not available individually but as part of an assembly.

** The grinding wheels provided with the 726100 may be purchased from Norton Industrial or a local dealer. Refer to the following codes when ordering:*

UPC # 07660788282 Aluminum Oxide General Purpose (White), 8", 100 Grit

UPC # 07660705422 Norton 3X High Performance (Blue), 8", 80 Grit

14.0 Electrical Connections

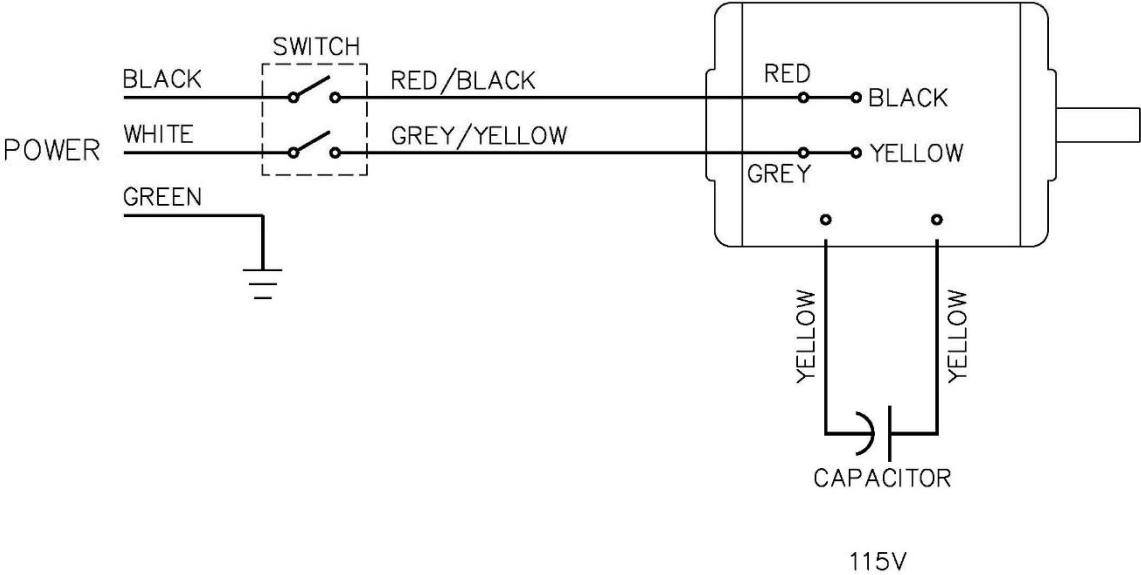



427 New Sanford Road
LaVergne, Tennessee 37086
Phone: 800-274-6848
www.jettools.com